

INTEGRITY SERIES SUMMIT TRAINER (CLSL)

OPERATION MANUAL

M051-00K68-A035



LifeFitness
WHAT WE LIVE FOR

CORPORATE HEADQUARTERS

5100 River Road
Schiller Park, Illinois 60176 • U.S.A.
847.288.3300 • FAX: 847.288.3703
800.735.3867 (Toll-free within U.S.A., Canada)
Global Website: www.lifefitness.com

INTERNATIONAL OFFICES

AMERICAS

North America Life Fitness Inc.

5100 N River Road
Schiller Park, IL 60176 U.S.A
Telephone: (847) 288 3300
Fax: (847) 288 3703
Service Email: commercialservicereply@lifefitness.com
Sales/Marketing Email: commercialsales@lifefitness.com
Operating Hours: 7:00 am - 6:00 pm (CST)

Brazil

Life Fitness Brasil

Av. Cidade Jardim, 900
Jd. Paulistano
São Paulo, SP 01454-000
BRAZIL
SAC: 0800 773 8282
Telephone: +55 (11) 3095 5200
Fax: +55 (11) 3095 5201
Service Email: suporte@lifefitness.com.br
Sales/Marketing Email: lifefitness@lifefitness.com.br
Service Operating Hours:
9:00 - 17:00 (BRT) (Monday-Friday)
Store Operating Hours:
9:00 - 20:00 (BRT) (Monday-Friday)
10:00 - 16:00 (BRT) (Saturday)

Latin America & Caribbean*

Life Fitness Inc.

5100 N River Road
Schiller Park, IL 60176 U.S.A
Telephone: (847) 288 3300
Fax: (847) 288 3703
Service Email: customersupport@lifefitness.com
Sales/Marketing Email: commercialsales@lifefitness.com
Operating Hours: 7:00am-6:00pm (CST)

EUROPE, MIDDLE EAST, & AFRICA (EMEA)

Netherlands & Luxemburg

Life Fitness Atlantic BV

Bijdorplein 25-31
2992 LB Barendrecht
THE NETHERLANDS
Telephone: (+31) 180 646 666
Fax: (+31) 180 646 699
Service Email: service.benelux@lifefitness.com
Sales/Marketing Email:
marketing.benelux@lifefitness.com
Operating Hours: 9.00h-17.00h (CET)

United Kingdom & Ireland

Life Fitness UK LTD

Queen Adelaide
Ely, Cambs, CB7 4UB
Telephone: General Office (+44) 1353.666017
Customer Support (+44) 1353.665507
Fax: (+44) 1353.666018
Service Email: uk.support@lifefitness.com
Sales/Marketing Email: life@lifefitness.com
Operating Hours:
General Office: 9.00am - 5.00pm (GMT)
Customer Support: 8.30am - 5.00pm (GMT)

Germany & Switzerland

Life Fitness Europe GMBH

Siemensstraße 3
85716 Unterschleißheim
GERMANY
Telephone: (+49) 89.31 77 51.0 (Germany)
(+41) 0848 000 901 (Switzerland)
Fax: (+49) 89.31 77 51.99 (Germany)
(+41) 043 818 07 20 (Switzerland)
Service Email: kundendienst@lifefitness.com
Sales/Marketing Email: kundenberatung@lifefitness.com
Operating Hours: 08.30 -16.30h (CET)

Austria

Life Fitness Austria

Vertriebs G.m.b.H.
Dückerstraße 7-9/3/36
1220 Vienna
AUSTRIA
Telephone: (+43) 1.61.57.198
Fax: (+43) 1.61.57.198.20
Service Email: kundendienst@lifefitness.com
Marketing/Sales Email: kundenberatung@lifefitness.com
Operating Hours: 9.00h-17.00h (MEZ)

Spain

Life Fitness IBERIA

C/Frederic Mompou 5, 1ª^a
08960 Sant Just Desvern Barcelona
SPAIN
Telephone: (+34) 93.672.4660
Fax: (+34) 93.672.4670
Service Email: info.iberia@lifefitness.com
Sales/Marketing Email: info.iberia@lifefitness.com
Operating Hours:
9.00h-18.00h (Monday-Thursday)
8.30h-15.00h (Friday)

Belgium

Life Fitness Benelux NV

Parc Industriel de Petit-Rechain
4800 Verviers
BELGIUM
Telephone: (+32) 87 300 942
Fax: (+32) 87 300 943
Service Email: internationalcustomersupport@lifefitness.com
Sales/Marketing Email: marketing.benelux@lifefitness.com
Operating Hours: 9.00h -17.00h (CET)

Italy

Life Fitness Europe GmbH

Siemensstraße 3
85716 Unterschleißheim
GERMANY
Telephone: (+39) 02-55378611
Service: 800438836 (In Italy)
Fax: (+39) 02-55378699
Service Email: assistenza@lifefitness.com
Sales/Marketing Email: info@lifefitnessitalia.com
Operating Hours: 08:30 - 16:30h (CET)

All Other EMEA countries & distributor business C-EMEA*

Bijdorplein 25-31
2992 LB Barendrecht
THE NETHERLANDS
Telephone: (+31) 180 646 644
Fax: (+31) 180 646 699
Service Email: service.db.cemea@lifefitness.com
Sales/Marketing Email:
marketing.db.cemea@lifefitness.com
Operating Hours: 9.00h-17.00h (CET)

ASIA PACIFIC (AP)

Japan

Life Fitness Japan

Nippon Brunswick Bldg., #8F
5-27-7 Sendagaya
Shibuya-Ku, Tokyo
Japan 151-0051
Telephone: (+81) 3.3359.4309
Fax: (+81) 3.3359.4307
Service Email: service@lifefitnessjapan.com
Sales/Marketing Email: sales@lifefitnessjapan.com
Operating Hours: 9.00h-17.00h (JAPAN)

China and Hong Kong

Life Fitness Asia Pacific LTD

Room 2610, Miramar Tower
132 Nathan Road
Tsimshatsui, Kowloon
HONG KONG
Telephone: (+852) 2891.6677
Fax: (+852) 2575.6001
Service Email: HongKongEnquiry@lifefitness.com
Sales/Marketing Email: ChinaEnquiry@lifefitness.com
Operating Hours: 9.00h-18.00h

All Other Asia Pacific countries & distributor business Asia Pacific*

Room 2610, Miramar Tower
132 Nathan Road
Tsimshatsui, Kowloon
HONG KONG
Telephone: (+852) 2891.6677
Fax: (+852) 2575.6001
Service Email: HongKongEnquiry@lifefitness.com
Sales/Marketing Email: ChinaEnquiry@lifefitness.com
Operating Hours: 9.00h-18.00h

* Also check www.lifefitness.com for local representation or distributor/dealer.

TABLE OF CONTENTS

Section	Description	
1.	Getting Started	5
1.1	Important Safety Instructions	5
1.2	Setup	7
2.	Console Overlay	8
2.1	Console Overlay Overview	8
2.2	Console Overlay Descriptions	9
2.3	Reading Rack and Bottle Holder	12
3.	Heart Rate Zone Training®	13
3.1	Why Heart Rate Zone Training® Exercise	13
3.2	Heart Rate Monitoring	14
4.	The Workouts	16
4.1	Workout Overviews	16
4.2	Using the Workouts	18
4.3	Workout Descriptions	22
4.4	Personal Trainer Workouts	30
4.5	Logging On to the Network	30
4.6	Using the Life Fitness Summit Trainer	31
5.	System Menu	32
5.1	Entering and Using the System Menu	32
5.2	Manager's Configuration Settings	33
6.	Service and Technical Data	35
6.1	Preventive Maintenance Tips	35
6.2	Preventive Maintenance Schedule	36
6.3	Troubleshooting the Optional Polar® Telemetry Heart Rate Chest Strap	37
6.4	Troubleshooting the iPod®	39
6.5	Troubleshooting the Lifepulse™ System Sensors	41
6.6	How to Obtain Product Service / Serial Number Location	41
7.	Specifications	42
7.1	CLSL Summit Trainer Specifications	42
7.2	CLSL Summit Trainer Warranty Information	43

Before using this product, it is essential that this ENTIRE operation manual and ALL installation instructions be read. It describes equipment setup and instructs members on how to use it correctly and safely.

Avant toute utilisation de ce produit, il est indispensable de lire ce manuel d'utilisation dans son INTÉGRALITÉ, ainsi que TOUTES les instructions d'installations.

Ce manuel explique comment installer l'équipement et comment l'utiliser correctement et sans danger.

FCC Warning - Possible Radio / Television Interference

NOTE: *This equipment has been tested and found to comply with the limits for a Class A digital device, pursuant to part 15 of the FCC rules. These limits are designed to provide reasonable protection against harmful interference when the equipment is operated in a commercial environment. This equipment generates, uses and can radiate radio frequency energy, and if not installed and used in accordance with the operation manual, may cause harmful interference to radio communications. Operation of this equipment in a residential area is likely to cause harmful interference in which case the user will be required to correct the interference at his own expense.*

Class S (Studio): Professional and / or commercial use.



CAUTION: Any changes or modifications to this equipment could void the product warranty.



MISE EN GARDE: Tout changement et toute modification de ce matériel peut annuler la garantie du produit.

Any service, other than cleaning or user maintenance, must be performed by an authorized service representative. There are no user serviceable parts.

This Operation Manual describes the functions of the following product:

Integrity Series Summit Trainer (CLSL)

See "Specifications" in this manual for product specific features.

Statement of Purpose: The Life Fitness Summit Trainer is an exercise machine that combines low-impact pedaling with push/pull arm motion to provide an efficient, effective total body workout.



CAUTION: Life Fitness STRONGLY recommends seeing a physician for a complete medical exam before undertaking an exercise program, particularly if the user has a family history of high blood pressure or heart disease, or is over the age of 45, or smokes, has high cholesterol, is obese, or has not exercised regularly in the past year.

If, at any time while exercising, the user experiences faintness, dizziness, pain, or shortness of breath, he or she must stop immediately.



MISE EN GARDE: Life Fitness conseille VIVEMENT de consulter un médecin pour subir un examen médical complet avant de commencer tout programme d'exercice, et tout particulièrement si l'utilisateur a des antécédents familiaux d'hypertension ou de troubles cardiaques, ou s'il a plus de 45 ans, s'il fume, s'il a du cholestérol, s'il est obèse ou n'a pas fait d'exercice régulièrement depuis un an.

Si, pendant l'utilisation de l'appareil, l'utilisateur ressent un malaise, des vertiges, des douleurs ou des difficultés à respirer, il doit cesser immédiatement.

1 GETTING STARTED

1.1 IMPORTANT SAFETY INSTRUCTIONS



SAFETY WARNING: The safety of the product can be maintained only if it is examined regularly for damage and wear. See Preventive Maintenance section for details.

- If this Life Fitness product does not function properly after it has been dropped, damaged, or even partially immersed in water, contact Life Fitness Customer Support Services for assistance.
- Always follow the console instructions for proper operation.
- Close supervision is necessary when used by children, invalids or disabled persons.
- Do not use this product outdoors, near swimming pools or in areas of high humidity.
- Never operate a Life Fitness product with the air openings blocked. Keep air openings free of lint, hair or any other obstructing material.
- Never insert objects into any opening in this product. If an object should drop inside, carefully retrieve it. If the item cannot be reached, contact Life Fitness Customer Support Services.
- Never place liquids of any type directly on the unit, except in the water bottle holder. Containers with lids are recommended.
- Wear shoes with rubber or high-traction soles. Do not use shoes with heels, leather soles, cleats or spikes. Make sure no stones are embedded in the soles.
- Keep all loose clothing, shoelaces and towels away from moving parts.
- Do not use this product in bare feet.
- Do not tip the unit on its side during operation.
- Keep the area around the Life Fitness product clear of any obstructions, including walls and furniture. Ensure that there is at least one foot of clearance in front of the Life Fitness Summit Trainer.
- Use caution when mounting or dismounting the Life Fitness Summit Trainer. Use the stationary handlebars whenever additional stability is required. While exercising, hold onto the moving arms.
- Never use the Life Fitness Summit Trainer while facing backward.
- Do not stand or sit on product shroud.

**SAVE THESE INSTRUCTIONS
FOR FUTURE REFERENCE.**

1 POINT DE DÉPART

1.1 CONSIGNES DE SÉCURITÉ IMPORTANTES



CONSIGNE DE SÉCURITÉ : pour un emploi sûr, le produit doit être inspecté régulièrement afin de s'assurer qu'il n'est pas usé ni endommagé. Consultez la section de Maintenance préventive pour obtenir de plus amples informations.

- Si l'appareil Life Fitness ne fonctionne pas correctement après avoir subi une chute, des dommages ou une immersion même partielle dans l'eau, contactez le service d'assistance clientèle de Life Fitness.
- Pour un fonctionnement correct, suivez toujours les instructions de la console.
- Une surveillance étroite est nécessaire en cas d'utilisation par des enfants, des personnes invalides ou handicapées.
- N'utilisez pas ce produit à l'extérieur, près d'une piscine ou dans endroits très humides.
- Ne faites jamais fonctionner de produit Life Fitness dont les bouches d'aération seraient bloquées. Maintenez-les exemptes de peluches, de cheveux ou de toute obstruction.
- N'insérez jamais d'objet dans les ouvertures de cet appareil. Si un objet tombe dedans, coupez l'alimentation électrique, débranchez le cordon de la prise et récupérez-le avec précaution. Si vous ne pouvez pas l'atteindre, consultez le service après-vente de Life Fitness.
- Ne placez jamais de liquides d'aucune sorte directement sur l'appareil, sauf si vous disposez d'un support ou d'un plateau pour accessoires. Il est recommandé d'utiliser des conteneurs munis d'un couvercle.
- Portez des chaussures avec semelles en caoutchouc ou antidérapantes. N'utilisez pas de chaussures à talons, de semelles en cuir ou à crampons. Assurez-vous qu'aucun caillou ne s'est incrusté dans les semelles.
- Maintenez les vêtements lâches, les lacets et les serviettes à l'écart des pièces en mouvement.
- N'utilisez pas cet appareil sans chaussures.
- Ne faites pas basculer l'appareil sur le côté tandis qu'il fonctionne.
- Maintenez la zone autour du produit Life Fitness exempte d'obstructions, y compris de murs et de meubles. Veillez à laisser au moins 30 cm d'espace autour du Life Fitness Summit Trainer.
- Procédez avec précaution lors du montage ou du démontage de la machine. Utilisez la barre fixe pour renforcer votre stabilité. Pendant les exercices, saisissez les bras mobiles.
- N'utilisez jamais cet appareil en vous tournant vers l'arrière.
- Ne pas se tenir debout ou s'asseoir sur linceul produit.

**CONSERVER CES INSTRUCTIONS
POUR TOUT USAGE ULTÉRIEUR.**

1.2 SETUP

Read the Operation Manual before setting up the Life Fitness Summit Trainer.

WHERE TO PLACE THE LIFE FITNESS® SUMMIT TRAINER

Follow all safety instructions in Section 1.1 and move the Life Fitness Summit Trainer to the location in which it will be used. See Section 7 for the dimensions of the footprint. Allow 1 foot of clearance in front of the Life Fitness Summit Trainer to allow for movement of the total body arms.

HOW TO STABILIZE THE LIFE FITNESS SUMMIT TRAINER

After placing the Life Fitness Summit-Trainer in position, check the unit for stability by attempting to rock the unit. Any slight rocking indicates that the unit must be leveled. There are a total of (5) feet on the Summit Trainer for stability. The (2) rear feet under the rear step should require no adjustment. The (1) middle leveler should be adjusted last and is only for support, not leveling. Check the (2) front levelers to determine which foot does not rest fully on the floor. Rotate the foot counter-clockwise to lower it. Recheck the stability and adjust again as needed until the unit is stable and no longer rocks. Lower the middle leveler until it contacts the floor. Lock the adjustment nut on both the (2) front and middle levelers by tightening the jam nut with a 17 mm wrench.

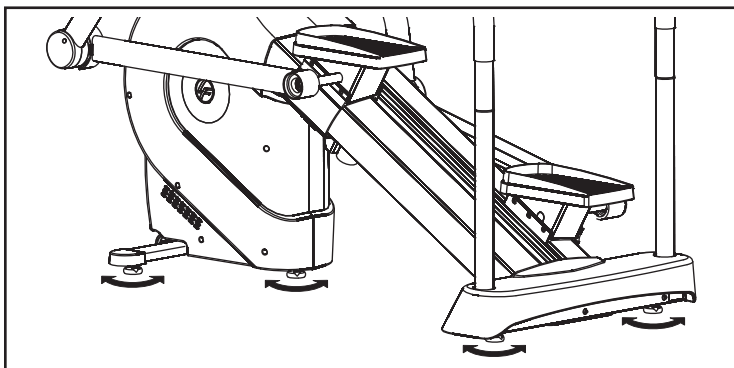

CHECK FOR POWER

The console is powered by a rechargeable 6-volt battery. Check the battery by pressing the START key. The console should light up, and the MESSAGE CENTER should display a prompt to set up a workout. If this does not occur, mount the Life Fitness Summit Trainer and begin pedaling. The console should then light up, making it possible to program a workout. Pedal for 10 to 20 minutes at 0.5 mph (0.8 kph) or faster during a workout to charge the battery. Afterwards, the pedal action during workouts keeps the battery charged. If the console still does not light, contact Life Fitness Customer Support Services (*see page one of this manual for more information*).

FITNESS AND ENTERTAINMENT NETWORKING

Two interchangeable network ports allow the Life Fitness Summit Trainer to be connected to a fitness entertainment system or a network, such as FitLinxx™ interactive fitness network.

- **Networking:** The built-in networking ports allow the unit to exchange workout information with a fitness network database.
- **Fitness Entertainment:** The network connection enables the console to power a third-party receiver for use with a service such as the Cardio Theater® entertainment system or the BroadcastVision™ entertainment system.

These ports are located on the back of the console and are enclosed by a removable cover. Any use of the ports for other than their intended purpose could void the product warranty.

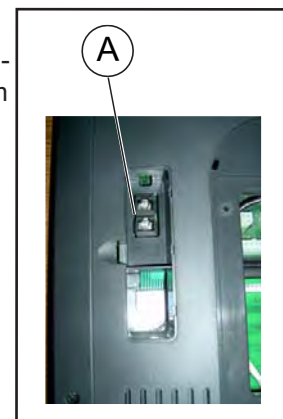

2 CONSOLE OVERLAY

2.1 CONSOLE OVERLAY OVERVIEW

The computerized display console on the Summit Trainer allows the user to tailor a workout to personal fitness abilities and goals and to monitor progress. With this easy-to-use console, the user can track fitness improvement from one workout to the next.

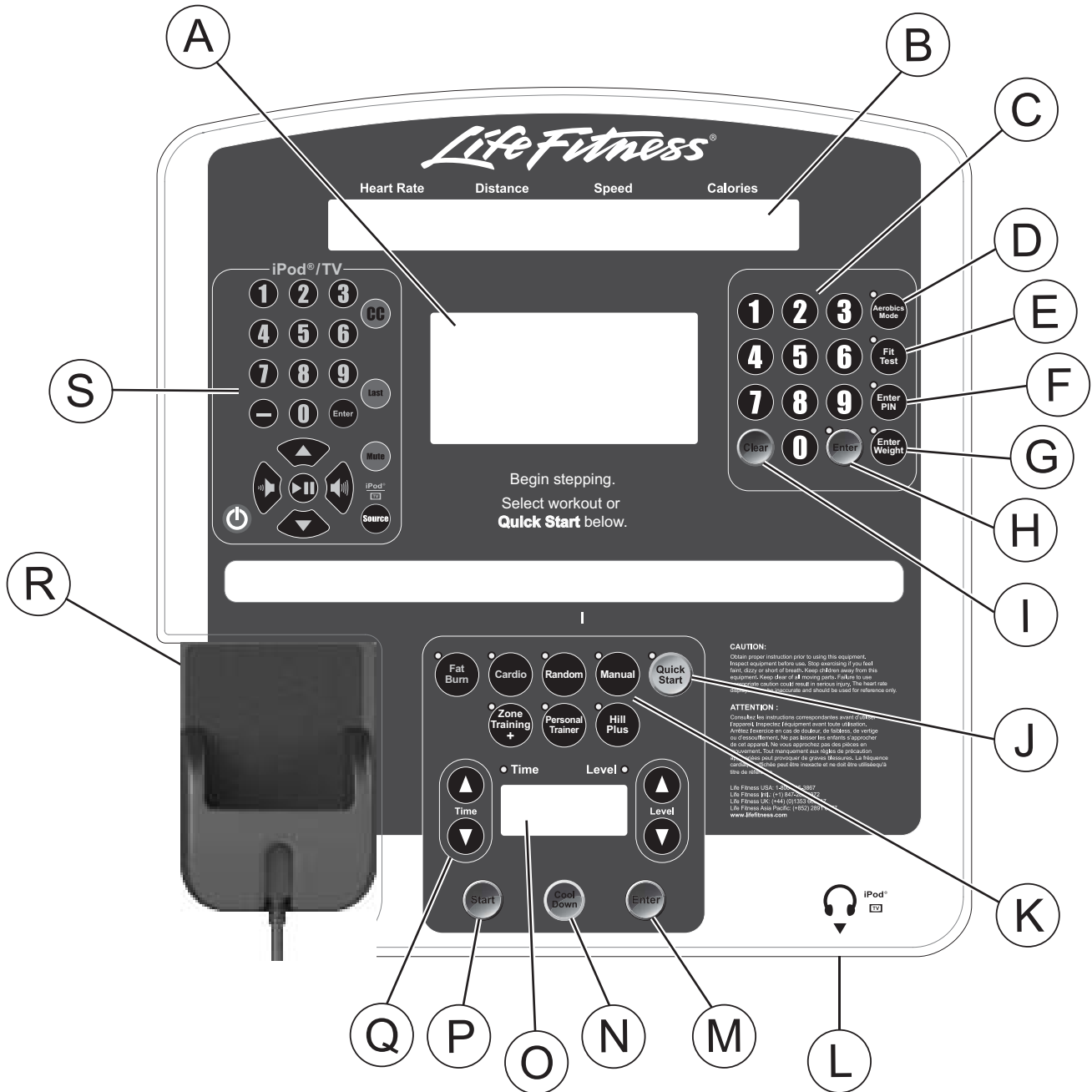

2.2 CONSOLE OVERLAY DESCRIPTIONS

- A. **WORKOUT PROFILE** window: This window displays shapes, made of columns of lights, that represent the levels of intensity in a workout-in-progress. The height of the first column on the left side of the window is proportional to the current level of intensity.

During a **FAT BURN, CARDIO, HEART RATE HILL, HEART RATE INTERVAL, or EXTREME HEART RATE** workout, which requires the use of a Polar® telemetry heart rate chest strap or the Lifepulse system sensors, the **WORKOUT PROFILE** window displays a flashing heart shape to request the user's heart rate signal. If the console does not detect a signal, the **MESSAGE CENTER** displays the prompt "NEED HEART RATE - PLACE HANDS ON SENSORS OR USE TELEMETRY STRAP". If the console does not receive the signal within three minutes, the workout automatically is converted to a **MANUAL** program.

- B. **MESSAGE CENTER**: This window displays step-by-step instructions for setting up a workout. During a workout, it displays statistics about the progress of the workout:

- **Heart Rate**: the detected heart rate if the user is wearing the chest strap or grasping the Lifepulse system sensors.
- **Distance**: the total distance traveled in miles (or kilometers if enabled).
- **Speed**: the pedaling speed or rate in miles per hour (or kilometers per hour if enabled).
- **Calories**: the number of calories burned since beginning the workout.

If configured to do so, the **MESSAGE CENTER** displays any or all of these three values each time the intensity level changes during the workout:

- **Calories per Hour**: the rate of calories burned per hour.
- **Watts**: effort level in Watts. The Watt is a unit of power output or the expression of the mechanical rate of work.
- **METs**: effort level in METs. The MET is an expression of the rate of work for the human body at rest, or a metabolic equivalent; one MET is approximately equal to the metabolism of a person at rest.

Note: *The Watts display and the Calories per Hour display cannot be turned on at the same time.*

- C. **NUMERIC keypad**: Use these keys to enter values, such as length of workout, weight, age, target heart rate, and intensity level. While a workout is in progress, numeric keys can be used to set new intensity levels or change the target heart rate in the **FAT BURN, CARDIO, HEART RATE HILL, HEART RATE INTERVAL, and EXTREME HEART RATE** workouts. The **ARROW** keys have a similar function, except that they change workout parameters by single increments.
- D. **AEROBICS MODE**: Press this key to activate a workout mode in which the **MESSAGE CENTER** displays prompts that vary the workload and emphasize different muscle groups during the workout. It can be used with any workout, except for **FAT BURN, CARDIO, HEART RATE HILL, HEART RATE INTERVAL or EXTREME HEART RATE**.
- E. **FIT TEST**: Press this key to select the **FIT TEST**, which measures cardiovascular fitness compared to other people of the same age and gender.
- F. **ENTER PIN** key: Log on to the FitLinxx Interactive Fitness Network using a dedicated PIN Number. A FitLinxx Interactive Fitness Network shall be supported through the CSAFE console port connector as a CSAFE Compatible Device.
- G. **ENTER WEIGHT** key: Press this key to enter a user weight during a workout. Use the **TIME ARROW** keys or the **NUMERIC keypad** to enter a weight value.
- H. **ENTER** key: Press this key to confirm entries of workout setup values, as displayed in the **MESSAGE CENTER**.
- I. **CLEAR** key: Press this key, when programming a workout, to clear incorrect data, such as weight or age, before pressing the **ENTER** key. Pressing **CLEAR** during a workout stops it immediately, at which point, the **MESSAGE CENTER** displays a summary of the workout, including total time elapsed, total distance traveled, and total calories burned. Pressing **CLEAR** a second time causes the **MESSAGE CENTER** to prompt the user for a new workout setup.
- J. **QUICK START** key: Press this key to begin a manual workout immediately, without having to select a workout program. Once the workout is in progress, use the **ARROW** keys or the **NUMERIC KEYPAD** to change the intensity level or workout duration as desired.

- K. **WORKOUT SELECTION keys:** Press any of these keys to select the program identified on the given key's label. These programs include: **FAT BURN, CARDIO, RANDOM, MANUAL, ZONE TRAINING +, PERSONAL TRAINER,** and **HILL PLUS.**
- L. **HEADPHONE JACK:** Headphones must be plugged into the Summit Trainer to access the sound for the iPod, TV, or audio compatible entertainment device. The jack is not a user-replaceable feature. Contact Life Fitness Customer Support Services for more information.
- M. **ENTER key:** Press this key to confirm entries of workout setup values, as displayed in the MESSAGE CENTER.
- N. **COOL DOWN key:** Workout programs end automatically in a Cool Down mode, which lowers the intensity level. Press the COOL DOWN key at any desired point during a workout to go immediately into Cool Down mode. In this phase of a workout the body begins to remove lactic acid and other accumulated by-products of exercise, which build up in muscles during a workout and contribute to muscle soreness. The console automatically adjusts each workout's Cool Down level according to the individual user's performance.
- O. **LEVEL / TIME WINDOW:** This window displays the programmed intensity level and the time elapsed since the start of the program.
- P. **START:** Press this key to activate the console for programming a new workout. The activated console lights up and displays "SELECT WORKOUT OR PRESS QUICK START". If no key is pressed for 15 seconds and the user stops pedaling, the console shuts down again.

Note: *The Life Fitness Summit Trainer's AutoStart feature also activates the console when the user steps on the pedals and begins pedaling.*

- Q. **ARROW keys:** A pair of UP and DOWN arrows is located on either side of the TIME/LEVEL window. When setting up a workout, use either set of arrows to change workout parameters displayed on the console, such as length of workout, weight, age, target heart rate, and intensity level. During a workout, pressing the ARROWS on the right (LEVEL) side of the display changes the target heart rate for **FAT BURN, CARDIO, HEART RATE HILL, HEART RATE INTERVAL,** and **EXTREME HEART RATE** workouts or the intensity level for other workouts.

Pressing the ARROWS on the left (TIME) side increases or decreases the workout duration. Pressing the arrows on the right (LEVEL) side increases or decreases the intensity level.

Note: *Whenever an arrow key is pressed during a workout, an increase (up arrow key) or decrease (down arrow key) is made to the corresponding parameter (level). The number that appears reflects that change. For example, if the user is at level 6 and presses the right up arrow key, the number 7 will appear, reflecting that the user has chosen a new level. If the change is desired, press ENTER to accept. If the change is not desired, the user has ten seconds to reset the level to the desired parameter, before the unit accepts the changed value and makes the appropriate adjustments.*

- R. **iPOD HOLDER:** Users can attach an iPod via a 30-pin connector. Use iPod/TV controls to play, or controls on the iPod itself to select a song or video and begin playing.

Note: *If a Life Fitness Attachable TV is not connected, users can view videos on the iPod.*

- S. **iPOD / TV KEYPAD:** The keys are used to provide control of the optional entertainment systems (such as a Life Fitness Attachable TV, iPod, and Cardio Theater). These keys are NOT used for workout programs.

iPOD / TV KEYPAD

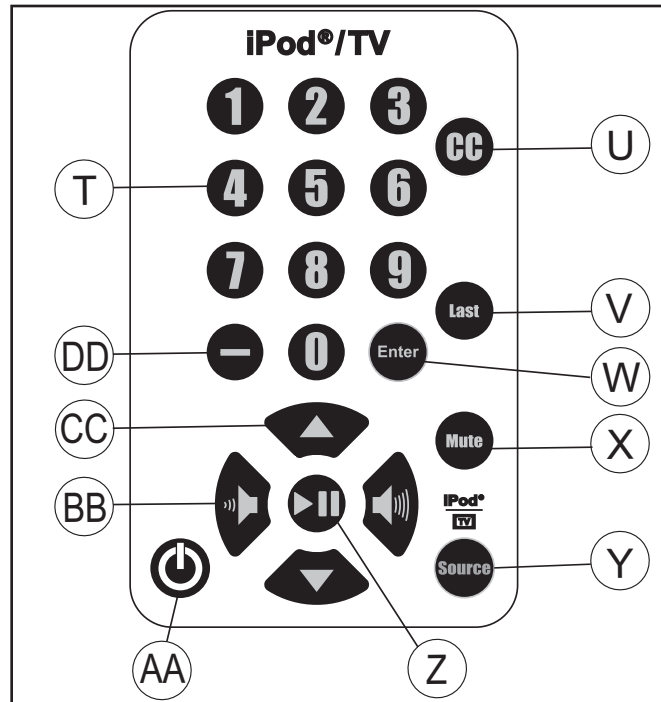

- T. NUMERIC keys: Press these keys to enter channels (*TV/CSAFE*).
- U. CC: Use this key to enable the Closed Caption Choice (*TV/CSAFE*).
- V. LAST: Press this key to see the last channel viewed (*TV only*).
- W. ENTER: Use this key to enter entertainment selections.
- X. MUTE: Press this key to turn off the sound (*Current Selected Source*).
- Y. TV/ IPOD SOURCE: Use this key to select TV, iPod, or optional AUX (auxillary) audio source.
- Z. PLAY / PAUSE: Use this key to Play or Pause the current track (*iPod only*).
- AA. POWER: Use this key to turn the power On and Off (*TV only*).
- BB. LEFT and RIGHT ARROW keys: Use these keys to adjust the volume up and down (*Current Selected Source*).
- CC. UP and DOWN ARROW keys: Use these keys to change channels (*TV*). Use these keys to select the next track and previous Track (*iPod*).
- DD. DIGITAL TV TUNER SUB-CHANNEL ENTRY key (-): Use this key to enter Digital TV channels.

2.3 READING RACK AND BOTTLE HOLDER

The water bottle holder (A) provides easy storage for water bottles and/or personal objects. Additionally, an integrated reading rack (B) for supporting a book or magazine is located at the base of the upper panel of the console.

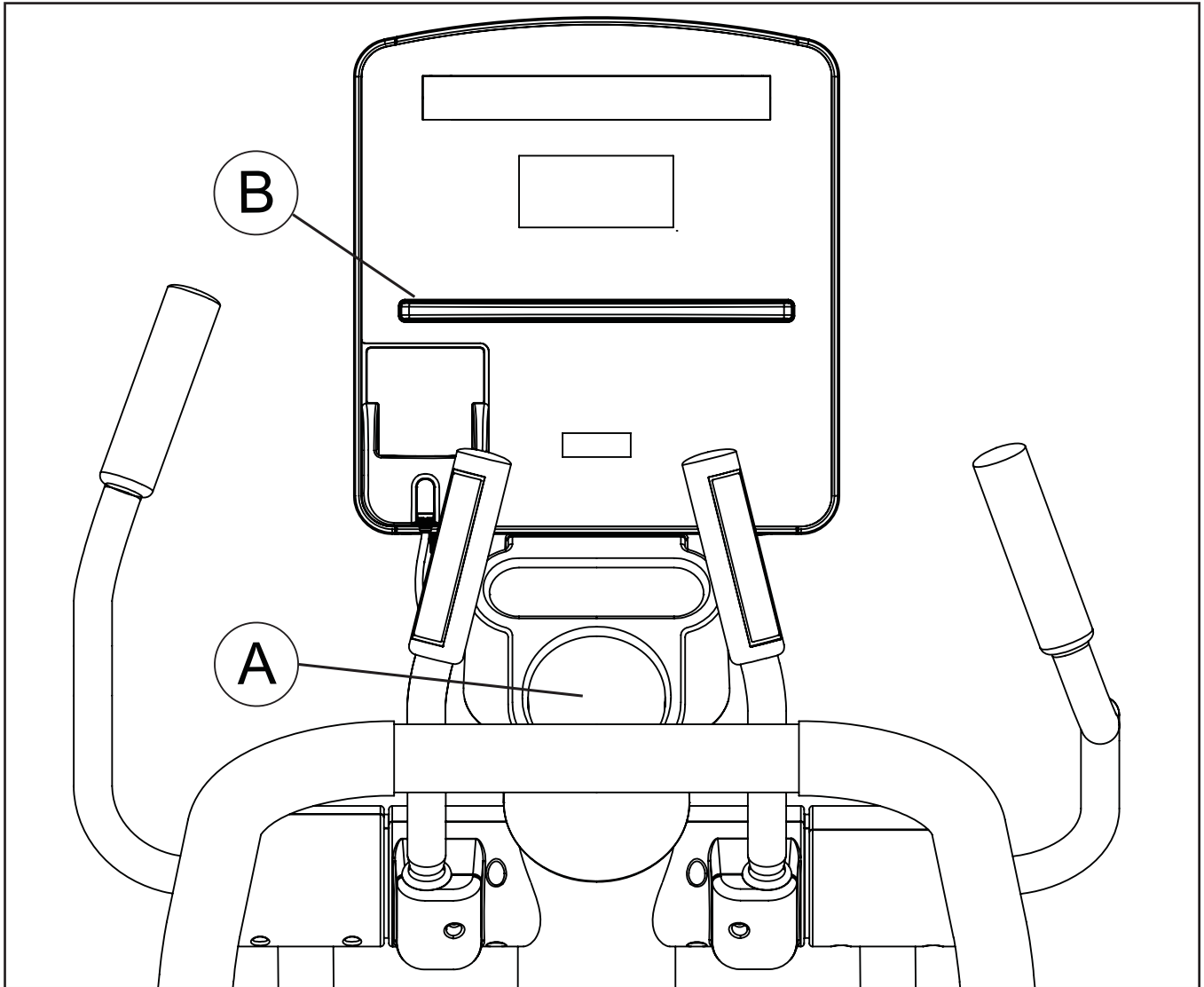

3 HEART RATE ZONE TRAINING®

3.1 WHY HEART RATE ZONE TRAINING® EXERCISE?

Research shows that maintaining a specific heart rate while exercising is the optimal way to monitor the intensity of a workout and to achieve maximum results. That is the idea behind the Life Fitness Heart Rate Zone Training® approach to exercise.

Zone Training identifies an exerciser's ideal heart rate range, or zone, for burning fat or increasing cardiovascular fitness. The zone is a percentage of the theoretical maximum (HRmax), and its value depends on the workout. The maximal heart rate formula is defined by the American College of Sports Medicine's "Guidelines for Exercise Testing and Prescription", 8th Edition, 2010. HRmax equals to 206.9 minus the total of 0.67 multiplied by a person's age.

$$\text{HR Max} = 206.9 - (0.67 * \text{age})$$

The Life Fitness Summit Trainer features exclusive workouts designed to take full advantage of the benefits of Heart Rate Zone Training+ exercise:

- FAT BURN
- HEART RATE HILL™
- EXTREME HEART RATE™
- CARDIO
- HEART RATE INTERVAL™

Each workout offers different benefits, as discussed in Section 4 *The Workouts*.

Note: Consulting a fitness trainer is recommended for defining specific fitness goals and designing a workout program.

To change the target heart rate during a workout, use the LEVEL arrow keys.

To switch between programs during a workout, use the WORKOUT SELECTION keys.

The Heart Rate Zone Training® workout programs measure heart rate. Wear the optional Polar® telemetry heart rate chest strap, or grip the Lifepulse™ sensors, to enable the Summit Trainer's on-board computer to monitor the heart rate during a workout. The computer automatically adjusts the resistance level to maintain the target heart rate based on the actual heart rate.

Age	Theoretical Maximum Heart Rate	65% (Fat Burn)	80% (Cardio)
10	200	130	160
20	194	126	155
30	187	121	149
40	180	117	144
50	173	113	139
60	167	108	133
70	160	104	128
80	153	100	123
90	147	95	117
99	141	91	112

Note: Reference the above chart for Theoretical Maximum Heart Rates and Target Heart Rates.

3.2 HEART RATE MONITORING

THE LIFEPULSE™ DIGITAL HEART RATE MONITORING SYSTEM

The patented Lifepulse system sensors are the built-in heart rate monitoring system on the Life Fitness Summit Trainer. For the most accurate reading possible, during a workout:

- Grasp the sensors (A) firmly.
- Hold each sensors at the vertical midpoint.
- Keep hands steady and in place.

The console displays the heart rate within 10 to 40 seconds after the user grasps the sensors. The following factors may affect a Lifepulse reading: incorrect hand placement on the sensors, upper body activity, lotion or dirt on hands, and excessive or insufficient pressure used when gripping the sensors.

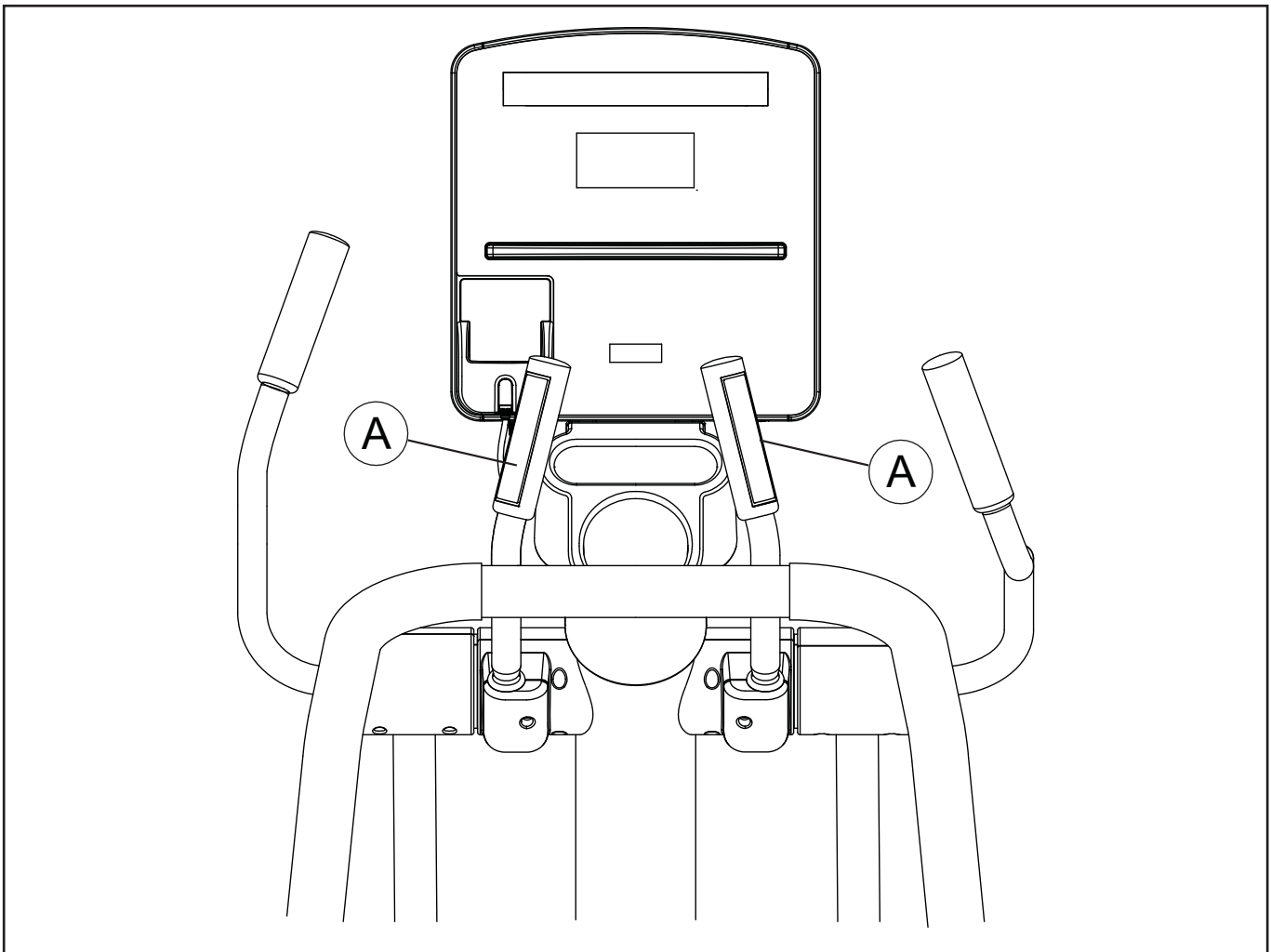

THE OPTIONAL POLAR® TELEMETRY HEART RATE CHEST STRAP

The Life Fitness Summit Trainer is equipped with Polar® telemetry, a heart rate monitoring system in which electrodes, pressed against the skin, transfer heart rate signals to the console. These electrodes are attached to a Polar telemetry heart rate chest strap that the user wears during the workout. The Polar telemetry heart rate chest strap is optional. Contact Life Fitness Customer Support Services to order.

See the diagram below for correct positioning of the Polar telemetry heart rate chest strap. The electrodes (A), which are the two grooved surfaces on the underside of the strap, must remain wet to transmit accurately the electrical impulses of the heart back to the receiver. Moisten the electrodes. Then, secure the Polar telemetry heart rate chest strap as high under the chest muscles as possible. The strap should be snug, but comfortable enough to allow for normal breathing.

The transmitter strap delivers an optimal heart rate reading when the electrodes are in direct contact with bare skin. However, it functions properly through a thin layer of wet clothing.

If it becomes necessary to re-moisten the Polar telemetry heart rate chest strap electrodes, grasp the center of the strap, pull it away from the chest to expose the two electrodes, and re-moisten them.

Note: If the Lifepulse system sensors are grasped while the chest strap is worn, and if the signals from the sensors are valid, the on-board computer uses these sensor signals for calculating the heart rate instead of those transmitted by the Polar telemetry heart rate chest strap.

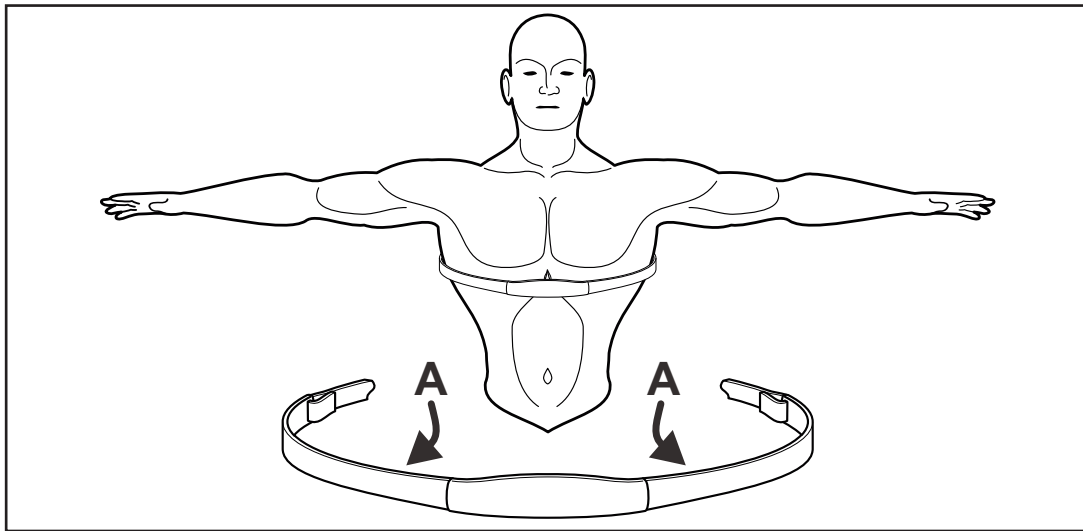

4 THE WORKOUTS

4.1 WORKOUT OVERVIEWS

The following workouts are pre-programmed for the Life Fitness Summit Trainer.

- ▶ **QUICK START** is the fastest way to begin exercising. After the QUICK START key is pressed, a constant-level workout begins. The intensity level does not change automatically.
- ▶ **MANUAL** is a constant effort workout in which the user can change the intensity level at any time. It is accessed with the MANUAL key.
- ▶ **RANDOM** is an interval training workout of constantly changing intensity levels that occur in no regular pattern or progression. It is accessed with the RANDOM key.
- ▶ **FAT BURN** is a low-intensity workout for burning a higher percentage of calories from fat. The user wears a Polar telemetry heart rate chest strap, or grasps the Lifepulse™ sensors continuously. The program adjusts the intensity level, based on the actual heart rate, to maintain the rate at 65% of the theoretical maximum. It is accessed with the FAT BURN key.
- ▶ **CARDIO** is a higher intensity workout for more fit users, maximizing cardiovascular benefits and total calories burned. The user wears a Polar telemetry heart rate chest strap or grasps the Lifepulse™ sensors continuously. The program adjusts the intensity level, based on the actual heart rate, to maintain the rate at 80% of the theoretical maximum. It is accessed with the CARDIO key.
- ▶ **LIFE FITNESS FIT TEST** estimates cardiovascular fitness and can be used to monitor improvements in endurance every 4-6 weeks. It is accessed by the FIT TEST key.

The following workouts are accessed by pressing the **HILL PLUS** key.

- ▶ **HILL** is an interval training workout. Intervals are periods of intense aerobic exercise separated by regular periods of lower-intensity exercise.
- ▶ **AROUND THE WORLD** is an interval-training workout in which the hills resemble scenes of various geographical areas.
- ▶ **CASCADES** is a two-peak workout in which intensity levels gradually increase and decrease.
- ▶ **FOOTHILLS** is a rolling hill workout with low intensity levels.
- ▶ **INTERVAL** is a HILL workout in which intensity levels rise and fall. The higher levels gradually incline toward a peak and then gradually decline.
- ▶ **KILIMANJARO** is a HILL workout in which the intensity levels gradually incline toward one ultimate peak and then gradually decline.
- ▶ **SPEED TRAINING** is a HILL workout in which the intensity level alternates between high and low levels very quickly to simulate a typical speed training workout.

The following workouts are accessed by pressing the **PERSONAL TRAINER** key:

- ▶ **CROSS-TRAIN AEROBICS** simulates the experience of working with a personal trainer. The MESSAGE CENTER displays prompts at different times to emphasize pushing, pulling, total body, lower body, speed changes, and forward/reverse motion. This versatile workout promotes maximum cross-training benefits.
- ▶ **PERSONAL TRAINER WORKOUTS** allow fitness club managers and other authorized personnel to create up to six custom workouts for the Life Fitness Summit Trainer. Options include CUSTOM, INTERVAL, HEART RATE, and HILL workouts.
- ▶ **LIFE FITNESS FIT TEST** estimates cardiovascular fitness and can be used to monitor improvements in endurance every 4-6 weeks.

The following workouts are accessed by pressing the **ZONE TRAINING+** key.

- ▶ **HEART RATE HILL™** takes the user through three different hills based on the target heart rate. The user wears a Polar telemetry heart rate chest strap or grasps the Lifepulse™ sensors continuously.
- ▶ **HEART RATE INTERVAL™** alternates between a hill and a valley based on the target heart rate. The user wears a Polar telemetry heart rate chest strap or grasps the Lifepulse™ sensors continuously.
- ▶ **EXTREME HEART RATE™** is an intense workout for more experienced users. It is designed to get the heart rate up and down as quickly as possible. The user wears a Polar telemetry heart rate chest strap or grasps the Lifepulse™ sensors continuously.

4.2 USING THE WORKOUTS

This section provides detailed information on setting up and using workouts. For quick-reference setup steps, see the chart at the end of the section.

TO BEGIN A WORKOUT

To mount the Life Fitness Summit Trainer, grasp the handles and carefully step on the pedals. To dismount, step off the pedals while still holding the handles. Then let go of the handles.

Without networking, press START or begin pedaling to activate the console. The MESSAGE CENTER displays, "SELECT WORKOUT OR PRESS ENTER TO BEGIN." If it displays a different message, press the CLEAR key twice in rapid succession.

With optional networking enabled, press START or begin pedaling to activate the console. The MESSAGE CENTER displays, "SELECT WORKOUT OR ENTER PIN USING ENTER PIN KEY". Either select a workout as described below, or log on to the networked exercise database, and then select a workout. To log onto the network, press ENTER PIN, then using the NUMERIC KEYPAD enter the correct digits of the ID number and press ENTER.

SELECTING AND USING QUICK START

QUICK START is the fastest way to begin exercising and bypasses the steps of selecting a specific workout program. At the MESSAGE CENTER prompt to select a workout, press the QUICK START key. The workout begins at an intensity level that remains the same unless manually changed.

SELECTING A WORKOUT

For **MANUAL, FAT BURN, CARDIO, RANDOM, and FIT TEST**: When prompted to select a workout, press the key labeled with the name of the desired workout.

For **HEART RATE HILL, HEART RATE INTERVAL, and EXTREME HEART RATE**: When prompted by the MESSAGE CENTER to select a workout, press the ZONE TRAINING+ key. The MESSAGE CENTER then displays the name of one of the zone training workouts. Press ENTER to select the displayed workout or continue to press the ZONE TRAINING+ key to display each of the other options. Press ENTER to select the desired workout.

For **CROSS-TRAIN AEROBICS and PERSONAL TRAINER WORKOUTS**: When prompted by the MESSAGE CENTER to select a workout, press the PERSONAL TRAINER key. The MESSAGE CENTER displays the name a workout. Press ENTER to select the displayed workout or continue to press the PERSONAL TRAINER key to display each of the other options. Press ENTER to select the desired workout.

For **HILL, AROUND THE WORLD, FOOTHILLS, INTERVAL, KILIMANJARO, CASCADES, and SPEED TRAINING**: When prompted by the MESSAGE CENTER to select a workout, press the HILL PLUS key. The MESSAGE CENTER then displays the name of the one of these workouts. Press ENTER to select the displayed workout or continue to press the HILL PLUS key to display each of the other options. Press ENTER to select the desired program.

ENTERING WEIGHT

When prompted by the MESSAGE CENTER to enter weight, use the ARROW keys to increase or decrease the displayed weight to the correct value (or key in the correct value with the NUMERIC KEYPAD) and press ENTER. The default weight is 150 pounds or 68 kilograms. The on-board computer calculates the number and rate of calories burned using the entered weight as well as the pedaling speed and resistance level.

ENTERING AGE

When prompted by the MESSAGE CENTER to enter age, use the ARROW KEYS to increase or decrease the displayed age to the correct value (or key in the correct value with the NUMERIC KEYPAD) and press ENTER.

Life Fitness Summit Trainer workout programs that set a target heart rate zone first calculate the user's theoretical maximum heart rate. The HRmax equals 206.9 minus the total of 0.67 multiplied by a person's age. The programs then calculate the target zone as a percentage of the theoretical maximum.

ENTERING TIME

When prompted by the MESSAGE CENTER to enter a time, use the ARROW keys to increase or decrease the displayed time to the desired value (or key in the desired value with the NUMERIC KEYPAD) and press ENTER.

SELECTING AND ADJUSTING THE RESISTANCE LEVEL

When prompted by the MESSAGE CENTER, use the ARROW keys to increase or decrease the displayed intensity level or target heart rate to the desired value (or key in the desired value with the NUMERIC keypad) and press ENTER. Adjust the level as needed or desired during the workout.

- **Resistance level:** The Life Fitness Summit Trainer provides a selection of 25 resistance levels. The resistance level appears in the WORKOUT PROFILE window as rows of lights arranged in columns. Selecting a low intensity level at first is recommended. As physical conditioning improves, the levels can increase.
- **Target heart rate:** Programs that calculate a target heart rate base this number on the age of the user and the type of workout. The user accepts or adjusts the rate when setting up the workout. During the workout itself, the program reads the heart rate, which is transmitted via the heart rate chest strap or the Lifepulse system sensors; it uses this data to adjust the resistance. Manually raising the rate increases the intensity of the cardiovascular exercise.

SELECTING A GOAL TYPE

Workouts can be programmed to target certain type of goals:

- Calories
- Distance
- Time in zone

The **Calories Goal** feature is designed to promote weight loss and weight control. The user sets a calorie goal during the workout setup. Once the goal is met, the workout automatically goes into a Cool Down Phase and ends afterward. To use this feature:

1. Press the PERSONAL TRAINER key when prompted to select a workout.
2. Continue to press the PERSONAL TRAINER key until the MESSAGE CENTER displays "CALORIES GOAL". Then press ENTER.
3. Enter the desired calorie goal value.
4. Select a workout.
5. Run through the set-up steps for the selected workout.
6. Begin the workout.

The **Distance Goal** feature is designed to build endurance. The user sets a distance goal during the workout setup. Once the goal is met, the workout automatically goes into a Cool Down Phase and ends afterward. To use this feature:

1. Press the PERSONAL TRAINER key when prompted to select a workout.
2. Continue to press the PERSONAL TRAINER key until the MESSAGE CENTER displays "DISTANCE GOAL".
3. Press ENTER.
4. Enter the desired distance goal value.
5. Select a workout.
6. Run through the set-up steps for the selected workout.
7. Begin the workout.

The **TIME IN ZONE GOAL** program enhances **FAT BURN**, **CARDIO**, **HEART RATE HILL**, **HEART RATE INTERVAL**, and **EXTREME HEART RATE** workouts by setting a certain duration within the target zone as a workout goal. The program automatically alters the resistance to maintain a pace that will meet that objective within that duration. Once the objective is met, the workout automatically goes into a Cool Down Phase. To use the Time In Zone Goal feature:

1. Press the **ZONE TRAINING+** key when prompted to select a workout.
2. Continue to press the **ZONE TRAINING+** key until the **MESSAGE CENTER** displays “**TIME IN ZONE GOAL**”. Then press **ENTER**.
3. Enter weight.
4. Select the duration for staying within the zone.
5. Select a **FAT BURN**, **CARDIO**, **HEART RATE HILL**, **HEART RATE INTERVAL**, or **EXTREME HEART RATE** workout.
6. Enter age.
7. Accept or change the target heart rate displayed by the **MESSAGE CENTER**.
8. Begin the workout.

SELECTING A WORKOUT MODE

One workout mode option on the Life Fitness Summit Trainer features an alternate way to vary workouts.

- **Aerobics Mode:** This workout mode simulates the experience of working out with a trainer. Throughout the workout, the **MESSAGE CENTER** displays prompts to vary the workload and emphasize different muscle groups, such as upper- and lower-body. This feature can be used with any workout (except for **FAT BURN**, **CARDIO**, **HEART RATE HILL**, **HEART RATE INTERVAL** or **EXTREME HEART RATE**). To select it, press the **AEROBICS MODE** key.

SWITCHING WORKOUTS “ON-THE-FLY”

It is possible, during a workout, to switch to another workout program. After a switch, the console retains all the progress information about the workout since its beginning. To change workouts “on the fly,” simply press the key for the desired new workout. This feature is available for all workouts except for **AROUND THE WORLD**, **KILIMANJARO**, **INTERVAL**, **CASCADES**, **SPEED TRAINING**, **FOOTHILLS**, and **PERSONAL TRAINER** workouts.

PAUSING WORKOUTS

To pause a workout, simply stop pedaling. To continue the workout, resume pedaling. The pause duration lasts 60 seconds, after which the console automatically shuts down.

ENDING WORKOUTS EARLY

To end a workout before the pre-set duration expires, press **CLEAR** once. The **MESSAGE CENTER** then displays a workout summary, which includes the distance travelled, the total calories burned, and other statistics. Press **CLEAR** a second time and the **MESSAGE CENTER** displays “**SELECT WORKOUT OR PRESS QUICK START**” for a new workout.

STEPS TO SETUP EACH WORKOUT

<p>QUICK START Press QUICK START Begin workout</p>	<p>INTERVAL Press HILL PLUS repeatedly until INTERVAL appears; press ENTER Enter weight Enter time Select level Begin workout</p>	<p>EXTREME HEART RATE™ Press ZONE TRAINING+ repeatedly until EXTREME HEART RATE appears; press ENTER Enter weight Enter time Enter age Accept / Enter target heart rate Begin workout</p>
<p>MANUAL Press MANUAL Enter weight Enter time Select level Begin workout</p>	<p>FOOTHILLS Press HILL PLUS repeatedly until FOOTHILLS appears; press ENTER Enter weight Enter time Select level Begin workout</p>	<p>PERSONAL TRAINER WORKOUTS Press PERSONAL TRAINER repeatedly until PERSONAL TRAINER WORKOUT appears; press ENTER Select the desired workout number, from 1 to 6; press ENTER Enter weight Begin workout</p>
<p>RANDOM Press RANDOM Enter weight Enter time Select level Begin workout</p>	<p>KILIMANJARO Press HILL PLUS repeatedly until KILIMANJARO appears; press ENTER Enter weight Enter time Select level Begin workout</p>	<p>LIFE FITNESS FIT TEST Press FIT TEST Enter weight Enter age Enter gender Select level Begin workout</p>
<p>FAT BURN Press FAT BURN Enter weight Enter time Enter age Accept target heart rate Begin workout</p>	<p>CASCADES Press HILL PLUS repeatedly until CASCADES appears; press ENTER Enter weight Enter time Select level Begin workout</p>	<p>CROSS TRAIN AEROBICS Press PERSONAL TRAINER repeatedly until X-TRAIN AEROBICS appears; press ENTER Enter weight Enter time Select level Begin workout</p>
<p>CARDIO Press CARDIO Enter weight Enter time Enter age Accept target heart rate Begin workout</p>	<p>SPEED TRAINING Press HILL PLUS repeatedly until SPEED TRAINING appears; press ENTER Enter weight Enter time Select level Begin workout</p>	<p>HILL Press HILL PLUS repeatedly until HILL appears, press ENTER Enter weight Enter time Select level Begin workout</p>
<p>HEART RATE HILL™ Press ZONE TRAINING+ repeatedly until HEART RATE HILL appears; press ENTER Enter weight Enter time Enter age Accept/Enter target heart rate Begin workout</p>	<p>AROUND THE WORLD Press HILL PLUS repeatedly until AROUND THE WORLD appears; press ENTER Enter weight Enter time Select level Begin workout</p>	<p>HEART RATE INTERVAL™ Press ZONE TRAINING+ repeatedly until HEART RATE INTERVAL appears; press ENTER Enter weight Enter time Enter age Accept/Enter target heart rate Begin workout</p>

4.3 WORKOUT DESCRIPTIONS

QUICK START

QUICK START is the fastest way to begin exercising and bypasses the steps of selecting a specific workout program. The intensity level for the workout is set automatically and remains the same unless manually changed. To change the level, use the LEVEL arrow keys or use the NUMERIC KEYPAD to enter a higher or lower level number.

MANUAL

The **MANUAL** program sets an intensity level that does not change automatically. While the workout is in progress, raise or lower the intensity level as desired using the ARROW keys.

RANDOM

The **RANDOM** program creates a terrain of hills and valleys that varies with each workout. More than one million different patterns are possible.

FAT BURN

The **FAT BURN** workout is designed to maintain a user's heart rate at 65% of the theoretical maximum (HRmax) for optimal results. Throughout the workout, the user wears a Polar telemetry heart rate chest strap or grasps the Lifepulse™ sensors. If the user is not wearing a Polar telemetry heart rate chest strap, the WORKOUT PROFILE WINDOW displays a heart shape, and the MESSAGE CENTER displays a prompt to grasp the sensors. The console continuously monitors and displays the heart rate, adjusting the intensity level of the Summit Trainer to reach and maintain the target. This system eliminates over-training and under-training, and it maximizes the aerobic benefits of exercise by using the body's fat stores for fuel.

CARDIO

The **CARDIO** workout is virtually identical to **FAT BURN**, however the target heart rate is calculated at 80% of the theoretical maximum (HRmax). The higher target promotes cardiovascular improvement by placing a heavier workload on the heart muscle.

HILL

The Life Fitness-patented **HILL** workout offers a variety of configurations for interval training. Intervals are periods of intense cardiovascular exercise separated by regular periods of lower-intensity exercise. The **WORKOUT PROFILE** window represents these high and low intervals as columns of illuminated LEDs, which together have the appearance of hills and valleys. The computerized interval training workout has been scientifically demonstrated to promote greater cardiorespiratory improvement than steady-pace training.

The **HILL** workout goes through four phases, each marked by different intensity levels. The **WORKOUT PROFILE** window displays the progress of these phases. As noted in the descriptions below, the heart rate should be measured at two stages in the workout to gauge its effectiveness. Wear the Polar telemetry heart rate chest strap or continuously grip the Lifepulse™ handles. The **MESSAGE CENTER** does not display a request for a heart rate measurement, as it does with **CARDIO**, **FAT BURN** and the **HEART RATE ZONE TRAINING** programs.

1. **Warm-up** is a phase of low, gradually rising resistance, which brings the heart rate into the lower end of the target zone and increases respiration and blood flow to working muscles.
2. **Plateau** increases the intensity slightly and keeps it steady, to bring the heart rate to the low end of the target zone. Check the heart rate at the end of this phase.
3. **Interval Training** is a series of increasingly steeper hills alternating with valleys or stints of recovery. The heart rate should rise to the high end of the target zone. Check the heart rate at the end of this phase.
4. **Cool Down** is a low-intensity phase that allows the body to begin removing lactic acid and other exercise by-products which build up in muscles and contribute to soreness.

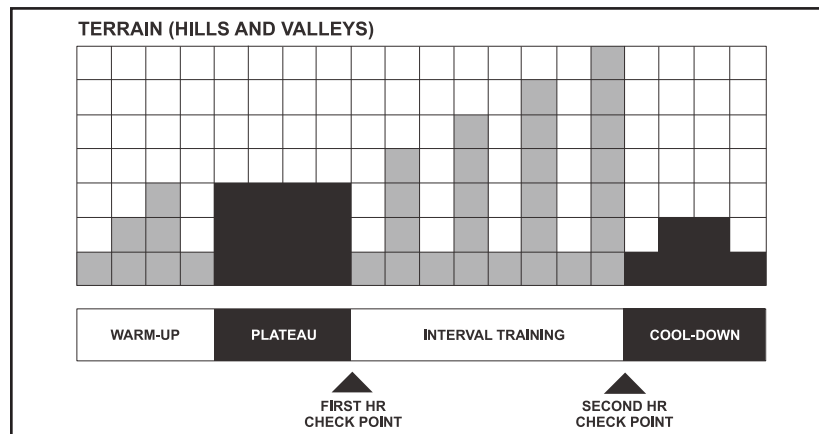

Each column, as seen in the **WORKOUT PROFILE WINDOW** and the chart above, represents one interval. The overall duration of the workout determines the length of each interval. Each workout is made up of 20 intervals, so the duration of each interval is equal to the duration of the entire workout divided by 20.

1 to 9 minutes: A workout with a duration of less than 10 minutes is insufficient for the **HILL** program to complete all four phases adequately. The program therefore condenses a workout of this duration at various stages.

10 to 19 minutes: The interval durations initially are set at 30 seconds for a 10-minute workout. For every minute over 10, each interval increases by three seconds. A 15-minute workout consists of 20 intervals at 45 seconds each.

20 to 99 minutes: All intervals last 60 seconds. If the user adds minutes to the pre-set duration while the workout is in progress, the program adds hills and valleys that are identical to the first eight intervals of the Interval Training phase. This pattern repeats until the workout is completed.

HEART RATE HILL™

This program combines the standard **HILL** workout profile with the concept of Heart Rate Zone Training. The default target heart rate is calculated as 80% of the theoretical maximum (HRmax), but the user can adjust the target rate during the workout setup. All hills and valleys are percentages of HRmax. The workout consists of three hills that target three heart rate goals:

- The first hill brings the heart rate to 70% of HRmax.
- The second hill increases the rate to 75% of HRmax.
- The third hill matches the Target Heart Rate bringing the heart rate to 80% of HRmax.

The valley is always defined as 65% of HRmax.

After a standard three-minute warm-up, the workout progresses toward the first hill and heart rate goal. Once the user reaches 70% of HRmax, the hill continues for one minute. When the minute expires, the level decreases into a valley. Once the user's heart rate falls to 65% of HRmax, the valley continues for one minute, then the next hill begins with its corresponding heart rate goal. After the user completes the third hill/valley pair, the program returns to the first hill and repeats the cycle as long as the duration allows. At the end of the duration, the workout goes into a cool down phase. If the heart rate goes above the theoretical maximum for more than 45 seconds, the Summit Trainer automatically goes into pause mode. The program does not proceed to a new heart rate goal until the user reaches the current goal.

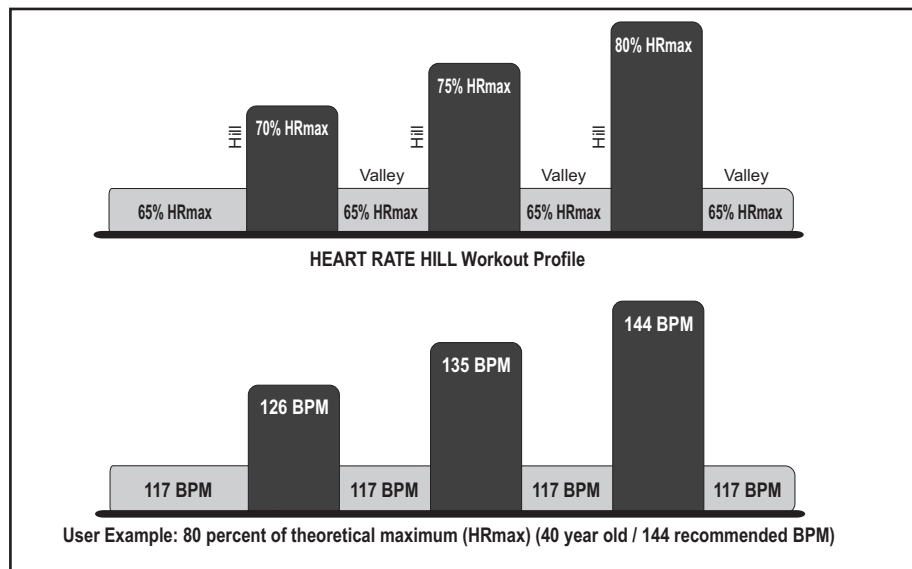

HEART RATE INTERVAL™

This program also combines the standard **HILL** workout profile with the concept of Heart Rate Zone Training. The default target heart rate is calculated as 80% of the theoretical maximum (HRmax), but the user can adjust the target rate during the workout setup. The workout alternates between a hill, which brings the heart rate up to the target rate of 80% of HRmax, and a valley which brings the heart rate down to 65% of HRmax. After a standard three-minute warm-up, the workout progresses toward the first hill and heart rate goal. Once the goal is reached, the hill continues for three minutes, then the level decreases into a valley. Once the 65% of HRmax goal is reached, the valley continues for three minutes, after which the next hill begins. The user's fitness level determines the number of hills and valleys encountered within the duration. At the end of the duration, the workout goes into a cool down phase. If the heart rate goes above the theoretical maximum for more than 45 seconds, the Summit Trainer automatically goes into pause mode. The program does not proceed to a new heart rate goal until the user reaches the current goal.

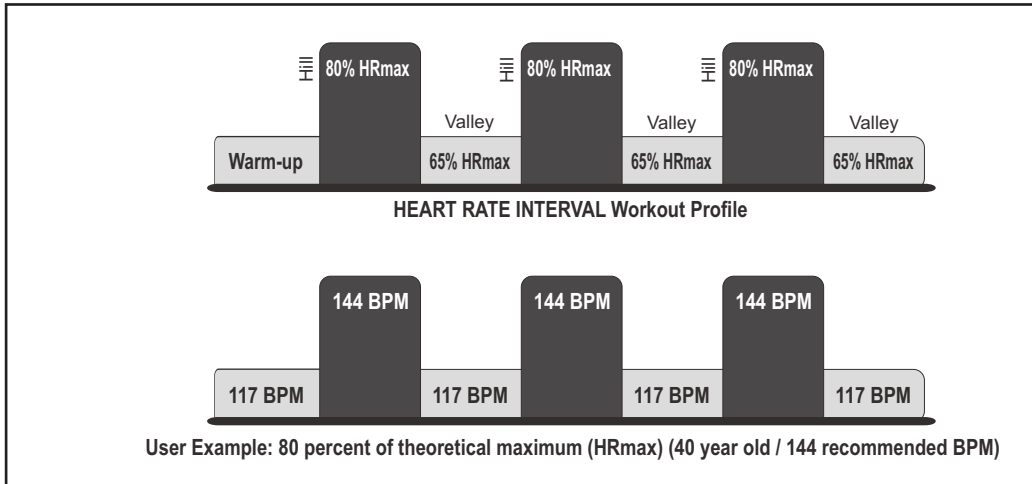

EXTREME HEART RATE™

This intense, varied workout is designed to help more experienced users to break through fitness improvement plateaus. The workout alternates between two target heart rates as quickly as possible. The effect is similar to that of running sprints. The user must wear a Polar telemetry heart rate chest strap or grip the Lifepulse™ sensors throughout the workout.

When setting up the workout, the user enters a target heart rate. After a standard three-minute warm-up, the intensity increases, until the user reaches the target heart rate goal of 85% of the theoretical maximum (HRmax). That target rate is maintained for a stabilizing period. Then, the intensity decreases. When the heart rate falls to the 65% of HRmax goal, it is maintained there for a stabilizing period. The program repeats the alternating intensity levels, continuing this pattern throughout the duration. The program does not proceed to a new heart rate goal until the user reaches the current goal.

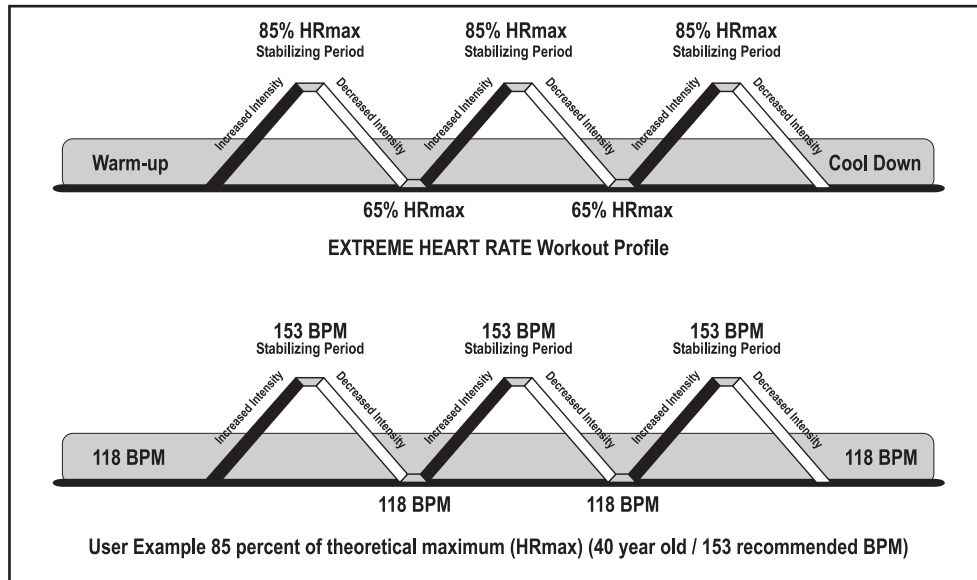

SIX PRE-SET WORKOUTS

AROUND THE WORLD, CASCADES, FOOTHILLS, INTERVAL, KILIMANJARO, and **SPEED TRAINING** are variations of the HILL workout. These workouts cannot be changed “on the fly.”

AROUND THE WORLD is an interval-training workout in which the hills resemble scenes of various geographical areas.

CASCADES is a two-peak workout in which intensity levels gradually increase and decrease.

FOOTHILLS is a rolling hill workout with low intensity levels.

INTERVAL is a HILL workout in which intensity levels rise and fall. The higher levels gradually incline toward a peak and then gradually decline.

KILIMANJARO is a HILL workout in which the intensity levels gradually incline toward one ultimate peak and then gradually decline.

SPEED TRAINING is a HILL workout in which the intensity level alternates between high and low levels very quickly to simulate a typical speed training workout.

FIT TEST

The Life Fitness Summit Trainer Fit Test program is another exclusive feature of this versatile product. The Fit Test workout estimates cardiovascular fitness and can be used to monitor improvements in endurance every four to six weeks. The user must grasp the Lifepulse hand sensors when prompted or wear a heart rate chest strap, as the test score calculation is based on a heart rate reading. The workout duration will be five minutes at the chosen resistance level. Immediately afterward, the console will take the user's heart rate reading, calculate a fitness score, and display the score in the MESSAGE CENTER.

The Fit Test is considered to be a submax VO_2 (volume of oxygen) test. It gauges how well the heart supplies oxygenated blood to the exercising muscles, and how efficiently those muscles receive oxygen from the blood. Physicians and exercise physiologists generally regard this test as a good measure of aerobic capacity.

To set up the Fit Test:

- Begin pedaling.
- Press the FIT TEST button.
- The message center will prompt for a user weight (ENTER WEIGHT). Use the NUMERIC KEYS or UP/DOWN ARROW KEYS to input your weight. Press ENTER to accept the weight.
- The message center will next prompt for a user age (ENTER AGE). Use the NUMERIC KEYS or UP/DOWN ARROW KEYS to input your age. Press ENTER to accept the age.
- The message center will next prompt for a user gender (SELECT GENDER). Using the UP/DOWN ARROW KEYS, select a gender. Press ENTER to accept the gender selection.
- The message center will next prompt for a workout level (ENTER LEVEL). Consult the following recommended fit test level chart for an appropriate effort level based on your age, gender and activity level. Use the NUMERIC KEYS or UP/DOWN ARROW KEYS to enter the corresponding level.
- As the test continues, a message will prompt the user to maintain a pedaling rate between 2.5 - 3.5 mph. The user must maintain this rate throughout the 5-minute test duration. After 16 seconds, if 2.5 - 3.5 mph is not maintained, the fit test will automatically terminate.

After the five-minute FIT TEST is completed, a FIT TEST score will be displayed.

FIT TEST PROGRAM SUGGESTED EXERTION LEVELS

	Inactive	Active	Very Active
Summit Trainer	L1-5 men	L4-10 men	L9-15 men
Fit Test Level	L1-4 women	L3-8 women	L7-12 women

Suggested exertion levels should be used as a guideline for setting up the Fit Test program. The goal is to elevate the user's heart rate to a level that is between 60%-85% of their theoretical maximum heart rate.

Within each suggested range, these additional guidelines can be used:

Lower Half of Range	Upper Half of Range
higher age	lower age
lower weight	higher weight*
shorter	taller

* In cases of excessive weight, use lower half of range

The computer will not accept:

- heart rates less than 52 or greater than 200 beats per minute
- body weights less than 75 pounds (34 kg) or greater than 400 pounds (181 kg)
- ages below 10 or over 99 years
- data input that exceeds human potential

If you make an error when entering any Fit Test data, you can correct it by pressing CLEAR, inputting the correct information and pressing ENTER.

It is important for you to take the Fit Test under similar circumstances each time. Your heart rate is dependent on many factors, including:

- amount of sleep the previous night (at least seven hours is recommended)
- time of day
- time you last ate (two to four hours after the last meal is recommended)
- time since you last drank a liquid containing caffeine or alcohol, or smoked a cigarette (at least four hours is recommended)
- time since you last exercised (at least six hours is recommended)

For the most accurate Fit Test results, you should perform the Fit Test on three consecutive days and average the three scores.

Note: To receive a proper Fit Test score, the work done must be within a training heart rate zone that is 60% to 85% of the theoretical maximum heart rate (HRmax). This program requires a constant exertion for accuracy, so it will not be allowed to resume if paused. This program will control level. Manual adjustment of level is not permitted.

The tables below list Fit Test results

RELATIVE FITNESS CLASSIFICATION FOR MEN					
	Estimated VO ₂ Max (ml/kg/min) Per Age Category				
Rating	20-29	30-39	40-49	50-59	60+
Elite	55+	52+	51+	47+	43+
Excellent	53-54	50-51	49-50	45-46	41-42
Very Good	50-52	48-49	46-48	43-44	39-40
Above Average	45-49	43-47	42-45	39-42	35-38
Average	40-44	38-42	37-41	34-38	31-34
Below Average	38-39	36-37	34-36	32-33	29-30
Low	35-37	34-35	32-33	29-31	26-28
Very Low	<35	<34	<32	<29	<26

RELATIVE FITNESS CLASSIFICATION FOR WOMEN					
	Estimated VO ₂ Max (ml/kg/min) Per Age Category				
Rating	20-29	30-39	40-49	50-59	60+
Elite	47+	44+	42+	37+	35+
Excellent	45-46	42-43	40-41	35-36	33-34
Very Good	43-44	40-41	38-39	33-34	31-32
Above Average	38-42	36-39	34-37	30-32	27-30
Average	33-37	31-35	30-33	26-29	24-26
Below Average	31-32	29-30	28-29	24-25	22-23
Low	28-30	27-28	25-27	22-23	20-21
Very Low	<28	<27	<25	<22	<20

Life Fitness developed this rating scale based on VO₂ max percentile distributions referenced in *American College of Sports Medicine's Guidelines for Exercise Testing and Prescription* (8th E. 2010). It is designed to provide a qualitative description of a user's VO₂ max estimation, and a means of assessing initial fitness level and tracking improvement.

4.4 PERSONAL TRAINER WORKOUTS

Using the console, fitness club managers and other authorized personnel can create up to six custom workouts for the Life Fitness Summit Trainer. Options include custom interval heart rate and hill workouts.

Interval Heart Rate: The trainer can design a workout that sets a different target heart rate for each interval and adjusts the resistance to the user's heart rate.

Hill: The trainer can create a custom hill workout that sets a different intensity level for each interval.

USING PERSONAL TRAINER WORKOUTS

Once **PERSONAL TRAINER** workouts are created, users can access them with the PERSONAL TRAINER key. Each custom workout is identified by a numeral, from 1 to 6. To select these workouts, press the PERSONAL TRAINER key. When prompted by the MESSAGE CENTER, press the number corresponding to the desired workout using the NUMERIC keypad. Then press ENTER and begin the workout.

CREATING A PERSONAL TRAINER WORKOUT

When the console is activated, hold down the COOL DOWN button and press the PERSONAL TRAINER button simultaneously.

Using the ARROW keys, scroll to, and select, the "PERSONAL TRAINER WORKOUT ENTRY" option and press ENTER. (If the alternate option, "ERASE PERSONAL TRAINER WORKOUTS", is selected, the computer deletes setup information for all **PERSONAL TRAINER** workouts and the MESSAGE CENTER displays "PERSONAL TRAINER WORKOUTS ERASED". Then the MESSAGE CENTER displays "PERSONAL TRAINER WORKOUT ENTRY".

Select a number, from 1 to 6, to identify the new workout. Use the NUMERIC keypad or the ARROW keys. Then press ENTER.

If a **PERSONAL TRAINER** workout already has been created for that number, the MESSAGE CENTER displays a prompt to either modify the workout or proceed to another number. Pressing the CLEAR key overwrites the previously created workout, making it possible to create a new workout for that number. Pressing ENTER bypasses the number and proceeds to another number.

If a **PERSONAL TRAINER** workout has not been created for a selected number, the MESSAGE CENTER displays the prompt, "BEGIN PERSONAL TRAINER WORKOUT CREATION".

The MESSAGE CENTER displays a prompt to enter a duration time for the entire workout. Using the NUMERIC keypad, enter a duration and press ENTER.

The MESSAGE CENTER displays a prompt to select the workout type. Options are "TARGET HEART RATE PERCENTAGE" or "LEVEL". The latter type is for custom hill workouts. Use the ARROW keys to toggle between the options, and press ENTER to select one of them.

The MESSAGE CENTER displays a prompt to select a target heart rate or an intensity level for the first interval, depending on the type of workout chosen in an earlier step. Use the ARROW keys or the NUMERIC keypad. A **PERSONAL TRAINER** workout consists of 30 intervals, so the length of each interval is equal to the workout duration value divided by 30. After entering the value, press ENTER. Repeat this set of steps for each of the following 29 intervals. To keep the preceding value for the current interval, simply press ENTER. At the end of this setup, the MESSAGE CENTER displays "PERSONAL TRAINER WORKOUT COMPLETED". The new **PERSONAL TRAINER** workout is ready to use.

Press the ENTER key to set up another workout. OR

Press the CLEAR key. The MESSAGE CENTER will display "SELECT WORKOUT OR PRESS QUICK START."

4.5 LOGGING ON TO THE NETWORK

When the Summit Trainer is connected to a network, the MESSAGE CENTER displays a prompt to log on with a personal ID number. Press ENTER PIN, then using the NUMERIC KEYPAD enter the correct digits of the ID number and press ENTER.

4.6 USING THE LIFE FITNESS SUMMIT TRAINER

SUMMIT TRAINER MOTION

The Life Fitness Summit Trainer has a user-defined stride length with a maximum of 26 inches, or 66 centimeters. The unit features dependent stepping action, which means that the pedal movements are dependent upon each other from left to right and from lower body to upper body. The benefits of these features include:

- Variety of stride lengths to accommodate shorter and taller users and to allow for a variety of motions
- Pull-push hip and knee action, which simulates actual climbing
- Development of muscular strength and endurance
- Excellent cardiovascular exercise

POSTURE DURING WORKOUTS

Begin stepping at a comfortable pace, taking either full or short steps, and keeping the back straight. Hold the handrails, the bullhorns, or the moving arms. It should be noted that resting on the handrails for support can offload weight and cause the Life Fitness Summit Trainer console to give inaccurate readings of calories burned.

There are five different body positions that can be used to activate different muscle groups.

1. **Upright, Lower Body.** With hands on handrails, maintain an upright, plumb-line position with your ears over shoulders, shoulders over hips and knees in line with toes. This upright posture promotes shorter strides. This position is good for beginners and recovery from advanced positions.
2. **Upright, Total Body.** With hands on moving arms, maintain an upright, plumb-line position as described above with your ears over shoulders, shoulders over hips and knees in line with toes. Keep your hips square to the console. This position is good for all levels and recovery from advanced positions.
3. **Forward Lean, Lower Body Only.** With hands on handrails, bend forward at hips and maintain an erect spine and lower body alignment. This position is good for intermediate to advanced users and recovery from advanced positions.
4. **Forward Lean, Total Body.** With hands on moving arms, bend forward at hips and maintain an erect spine and lower body alignment. The arms facilitate the leg movement, while the upper body push and pull encourages longer strides. This position is good for intermediate to advanced users.
5. **Racing Position, Lower Body Only.** With hands on the bull horns or elbows resting on the handrails, achieve a racing position by bending forward at hips while maintaining a flat back and lower body alignment of the knees and toes. This forward position promotes maximum stride length and hip extension. This position is good for advanced users for a short period of time.

BRAKING RESISTANCE

The Life Fitness Summit Trainer features speed-independent braking resistance. During a workout, the computer maintains a braking resistance that corresponds to the selected intensity level, regardless of the user's speed.

5 SYSTEM MENU

A special system menu is available to Managers and other authorized personnel to allow access to certain Information, diagnostics tests and configuration settings.

5.1 ENTERING AND USING THE SYSTEM MENU

The System Menu consists of 3 submenus including the Information submenu, Diagnostic submenu and Configuration submenu. To enter the System Menu press and hold down the '5' key on the numeric keypad then press the CLEAR key twice. Continue to hold down the '5' key until the MESSAGE CENTER displays the words CODE VER. X.XX. This is the Information menu which is the default submenu in the System Menu.

INFORMATION MENU (CODE VER X.XX)

The Information submenu will display information identifying the software version numbers and their associated part numbers as well as the version numbers of other installed software components. Use this menu when it is necessary to identify the version/part numbers installed on the product. The UP and DOWN arrow keys can be used to navigate through the list of items that may be displayed. Press the CLEAR key once to exit the Information Menu and hence the System Menu.

DIAGNOSTIC MENU (SERVICE MENU)

The Diagnostics submenu allows technicians to run system diagnostics. This menu can be entered from the Information Menu by pressing and holding the COOL DOWN key then pressing the ENTER key. The MESSAGE CENTER will display the words SERVICE MENU. Pressing the ENTER key will navigate forward through the list of diagnostic utilities while pressing the CLEAR key will navigate backward. Use the CLEAR key repeatedly to exit the Diagnostic Menu.

CONFIGURATION MENU (OPTIONAL SETTINGS)

The Configuration submenu allows the manager to configure options for the product. This menu can be entered from the Information Menu by pressing the ENTER key. The MESSAGE CENTER will display the words OPTIONAL SETTINGS. Pressing the ENTER key will navigate forward through the list of optional settings while pressing the CLEAR key will navigate backward. Use the CLEAR key repeatedly to exit the Configuration Menu. See the next page for a list of configuration options (Optional Settings).

5.2 MANAGER'S CONFIGURATION (OPTIONAL SETTINGS)

Setting	Default Value	Description
Maximum Workout Duration	60 Minutes	This feature allows the setting of maximum workout duration limits.
English / Metric Units	English <i>(International: Metric)</i>	This option sets the measurement unit type for weight, distance, and speed.
Pause Timeout	5 Minutes	This sets the maximum time during which a workout can remain in pause mode. <i>(Available on externally powered units)</i> .
WATTS Display	Off <i>(International: On)</i>	If this option is enabled, the MESSAGE CENTER displays the Watts equivalent of the pedal rate.
METS Display	Off	If this option is enabled, the MESSAGE CENTER displays the METs equivalent of the pedal rate.
Calorie Per Hour (CPH) Display	On <i>(International: Off)</i>	If this option is enabled, the MESSAGE CENTER displays the number of calories burned per hour during the workout.
Sleep Mode	Off	The Sleep Time configuration setting controls how long the console will stay powered up from the last key press but before actively engaging the product in exercise. This configuration applies to externally powered products only. Upon entry to this utility the current configuration setting shall be displayed. The UP / DOWN arrow keys shall allow incrementing / decrementing of the Sleep Time value in 1 minute increments respectively. The range of values for Sleep Time shall be 1 through 99 minutes and OFF.
Language Select	Off	If this option is enabled, users can set the User Language. Choices include: English, German, French, Spanish, Italian, Dutch, and Russian.
iPod Video	Enable	This feature allows control over allowing iPod video tracks to be played on the Life Fitness Attachable TV, if present. If enabled by selecting the On setting, and an iPod video track is selected, the video shall be routed to the TV. Otherwise, the video shall not.
AUX Source	Off	This setting allows control over whether or not an optional CSAFE compatible audio device attached to the CSAFE connector shall be selectable as an audio source with the Source Select key.
TV GAIN	2	This setting allows control over the console earphone volume range for the Life Fitness Attachable TV Source. The range of settings are from 0 (Low) to 7 (High).

USER LANGUAGE SELECT

If enabled, this option allows users to select the language by which to interact with the unit during a workout.

To use the option, enable User Language Select (see below).

Begin pedaling. The console will display the message "SELECT LANGUAGE USING ARROW KEYS". The user can select from a list of available languages using any of the arrow keys. Press enter when the desired language appears to select that language. A workout can now be started using the selected language. Selecting a language is not necessary to begin a workout. Simply press the QUICK START key to start a workout or any of the program keys to begin workout programming using the default language.

The user may select from the following languages:

English, German, French, Italian, Dutch, Spanish, and Russian.

To enable the User Language Select option, enter the Optional Settings (see Section 5.1). Scroll forward through the options using the ENTER key, or backward, using the CLEAR key until LANGUAGE SEL appears. Once LANGUAGE SEL appears in the Message Center, press any of the UP/DOWN ARROW keys to toggle the mode from OFF to ON.

6 SERVICE AND TECHNICAL DATA

6.1 PREVENTIVE MAINTENANCE TIPS

The Life Fitness Summit Trainer is backed by the engineering excellence and reliability of Life Fitness and is one of the most rugged and trouble-free pieces of exercise equipment on the market today. Commercial Life Fitness products are among the most popular of aerobic trainers in health clubs, colleges and military facilities the world over.

Note: *Safety of the equipment can be maintained only if the equipment is examined regularly for damage or wear. Keep the equipment out of use until defective parts are repaired or replaced. Pay special attention to parts that are subject to wear, as outlined below.*

REMARQUE: *pour conserver un matériel sûr, il convient de l'inspecter régulièrement afin de déceler tout signe d'usure ou d'endommagement. N'utilisez pas l'appareil tant que les pièces défectueuses n'ont pas été réparées ou remplacées. Portez une attention toute particulière aux pièces qui s'usent, comme indiqué ci-dessous.*

The following preventive maintenance tips will keep the Life Fitness Summit Trainer operating at peak performance:

- Locate the Life Fitness Summit Trainer in a cool, dry place.
- Clean the top surface of the pedals regularly.
- Keep the display console free of fingerprints and salt build-up caused by sweat.
- Clean the display console and all exterior surfaces with an approved or compatible cleaner (see *Life Fitness Approved Cleaners*) and a soft cotton cloth.
- Long fingernails may damage or scratch the surface of the console; use the pad of the finger to press the selection buttons on the console.
- Clean the housing and moving arms thoroughly on a regular basis.

LIFE FITNESS APPROVED CLEANERS

Two preferred cleaners have been approved by Life Fitness reliability experts: PureGreen 24 and Gym Wipes. Both cleaners will safely and effectively remove dirt, grime and sweat from equipment. PureGreen 24 and the Antibacterial Force formula of Gym Wipes are both disinfectants that are effective against MRSA and H1N1.

PureGreen 24 is available in a spray which is convenient for gym staff to use. Apply the spray to a microfiber cloth and wipe down the equipment. Use PureGreen 24 on the equipment for at least 2 minutes for general disinfection purposes and at least 10 minutes for fungus and viral control.

Gym Wipes are large, durable pre-moistened wipes to use on the equipment before and after workouts. Use Gym Wipes on the equipment for at least 2 minutes for general disinfection purposes.

Contact Customer Support Services to order these cleaners (1-800-351-3737 or email: customersupport@lifefitness.com).

LIFE FITNESS COMPATIBLE CLEANERS

Mild soap and water or a mild non-abrasive household cleaner can also be used to clean the display and all exterior surfaces. Use a soft cotton cloth only. Apply the cleaner to the cotton cloth before cleaning. DO NOT use ammonia or acid based cleaners. DO NOT use abrasive cleaners. DO NOT use paper towels. DO NOT apply cleaners directly to the equipment surfaces.

6.2 PREVENTIVE MAINTENANCE SCHEDULE

<i>ITEM</i>	<i>WEEKLY</i>	<i>MONTHLY</i>	<i>BI-ANNUALLY</i>
<i>Console Overlay</i>	<i>Clean</i>		<i>Inspect</i>
<i>Bottle Holder</i>	<i>Clean</i>	<i>Inspect</i>	
<i>Console Mounting Bolts</i>			<i>Inspect</i>
<i>Frame</i>	<i>Clean</i>		<i>Inspect</i>
<i>Plastic Covers</i>	<i>Clean</i>	<i>Inspect</i>	<i>Inspect</i>
<i>Lifepulse Sensors</i>	<i>Clean / Inspect</i>		

6.3 TROUBLESHOOTING THE OPTIONAL POLAR® TELEMETRY HEART RATE CHEST STRAP

Malfunction	Probable Cause	Corrective Action
Heart rate reading is initially detected and functioning normally but then is lost.	Use of personal electronic devices, such as cell phones and portable MP3 players, causes external noise interference.	Remove the source of noise or reposition the exercise equipment.
	Equipment is in close proximity to other sources of noise such as audio/ video equipment, fans, two way radios, and high voltage/high current power lines.	
Heart rate readings are abnormally elevated.	Television sets and/or antennas generate electromagnetic interference.	Move the Summit Trainer a few inches away from the probable cause, or move the probable cause a few inches away from the Summit Trainer, until the heart rate readings are accurate.
	Cell phones generate electromagnetic interference.	
	Computers generate electromagnetic interference.	
	Cars generate electromagnetic interference.	
	High voltage power lines generate electromagnetic interference.	
	Motor driven exercise equipment generates electromagnetic interference.	
	Another heart rate transmitter within 3 feet (1 meter) generates electromagnetic interference.	

TROUBLESHOOTING THE OPTIONAL POLAR® TELEMETRY HEART RATE CHEST STRAP (CONTINUED)

Malfunction	Probable Cause	Corrective Action
Heart rate reading is erratic or absent entirely.	Belt transmitter electrodes are not wet enough to pick up accurate heart rate readings.	Wet the belt transmitter electrodes (see Section 3.2).
	Belt transmitter electrodes are not laying flat against the skin.	Ensure the belt transmitter electrodes are laying flat against the skin (see Section 3.2).
	Belt transmitter needs cleaning.	Wash the belt transmitter with mild soap and water.
	Belt transmitter is not within 3 feet (1 meter) of the heart rate receiver.	Make sure the chest strap transmitter is within 3 feet (1 meter) of the heart rate receiver.
	Polar telemetry heart rate chest strap battery is depleted.	Contact Life Fitness Customer Support Services for instructions on how to have the Polar telemetry heart rate chest strap replaced.
	Polar telemetry heart rate chest strap did not lock in with the heart rate receiver.	<p>Make sure the Polar telemetry heart rate chest strap is applied and move closer to the heart rate receiver. Wait up to 10 seconds for the heart rate to display on the console.</p> <p>Notes:</p> <ol style="list-style-type: none"> 1. <i>Ensure proper adherence of the Polar telemetry heart rate chest strap to user's chest.</i> 2. <i>Ensure proper conductivity between the electrodes and user's chest.</i> 3. <i>If needed, use the Polar watch to verify chest strap's operation.</i>

6.4 TROUBLESHOOTING THE iPod®

Malfunction	Probable Cause	Corrective Action
Cannot control iPod using console keypad controls.	iPod is not fully connected due to interference with after market iPod protective cases.	Remove after market iPod protective case and reconnect.
Cannot hear iPod.	iPod paused.	Use iPod keypad controls on console to play a selection.
	Source selected is not currently set to iPod.	Press Source Select key until iPod is displayed.
	Mute key is pressed.	Press Mute key to unmute iPod source.
Cannot control iPod volume using console keypad controls.	Headphones are plugged into iPod instead of console headphone jack.	Plug headphones into console headphone jack.
	Volume control on iPod is being used with headphones plugged into console jack.	Use console iPod keypad volume controls.
Console displays a message that tells me to update my iPod firmware.	The iPod is not compatible due to its outdated firmware.	Visit www.apple.com for instructions on how to update your iPod device firmware.
Console displays a message that tells me "iPod COMMUNICATION TIMEOUT".	Use of older third generation (or earlier) iPod is not supported.	Use newer iPod model.
	iPod battery charge is extremely low.	Charge iPod to a minimum level before using.

TROUBLESHOOTING THE IPOD® (CONTINUED)

Malfunction	Probable Cause	Corrective Action
Cannot see iPod video on Life Fitness Attachable TV when played.	No TV is attached.	Attach a Life Fitness Attachable TV.
	Source select is switched to TV instead of iPod.	Press Source Select until the iPod message is displayed.
	iPod was connected while currently playing a video selection (<i>known Apple issue with iPod device firmware</i>).	Stop video play. Navigate to your video selection and restart video using either the iPod or console keypad controls.
	Audio track containing video begins playing as part of an audio playlist (<i>known Apple issue with iPod device firmware</i>).	Play track as a video selection.
Cannot navigate iPod menus.	Use of console keypad controls to navigate iPod menus.	Use iPod controls to navigate menus and select playlists. Use console keypad controls to Play/Pause and to change volume and tracks.
Cannot control iPod volume using iPod slider ring.	Use of iPod slider ring controls to adjust iPod volume when headphones are plugged into the console jack.	Use console volume arrow keys to control volume.
No controls to change playlist on console.	Use of console keypad controls to change playlist on iPod.	Select playlist on iPod using iPod controls.

6.5 TROUBLESHOOTING THE LIFEPULSE SYSTEM SENSORS

If the heart rate reading is erratic or missing, do the following:

- Dry the hands if necessary to prevent slipping.
- Apply hands to all four sensors; located at the front and back of the hand grips.
- Grasp the sensors firmly.
- Apply constant pressure around the sensors.

6.6 HOW TO OBTAIN PRODUCT SERVICE / SERIAL NUMBER LOCATION

1. Verify the symptom and review the operating instructions. The problem may be unfamiliarity with the product and its features and workouts.
2. Locate and write down the serial number of the unit which is located on the front stabilizer.
3. Contact Life Fitness Customer Support Services.

6.7 RECYCLING THE BATTERY

When this Life Fitness product is about to be discarded at the end of its useful life, the rechargeable battery must first be removed and recycled. If an optional external power supply is present, it must be disconnected before the battery is removed. To access the battery, remove either the right or left main shroud. To remove the battery, disconnect the cable, and remove the two screws holding the battery to the bracket.

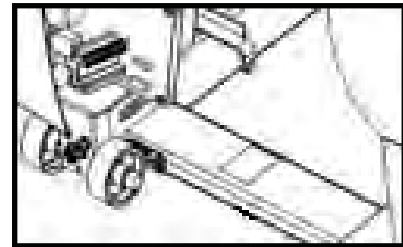
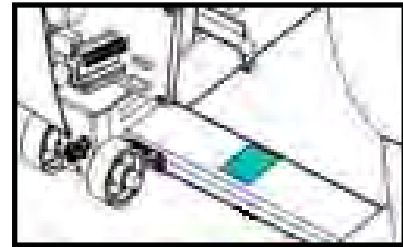

Remove plastic shroud to find small serial label location.

7 SPECIFICATIONS

7.1 LIFE FITNESS CLSL SUMMIT TRAINER SPECIFICATIONS

Designed use:	Heavy / Commercial
Maximum user weight:	400 pounds / 182 kilograms
Power requirements:	None
Console displays:	Elapsed time, total distance, total distance climbed, total calories burned, calories burned per hour, heart rate, target heart rate, Watts, METS, workout profile, resistance level, speed
Workouts, goals, & modes:	Quick Start, Manual, Cardio, Fat Burn, Heart Rate Hill™, Heart Rate Interval™, Extreme Heart Rate™ Random, Hill, Calories Goal, Distance Goal, Time-based Goal, Time in Zone Goal, Custom Workouts (6), Life Fitness Fit Test, Cool Down Mode, Speed Training, Around the World, Cascades, Foothills, Interval, Kilimanjaro, Aerobics Mode
Resistance levels:	25 (speed independent)
Pedal speed range:	0.5- 5.8mph (0.8 - 9.3kph)
Drive type:	Belt / alternator
Heart rate monitoring systems:	Patented Lifepulse™ digital contact heart rate and Polar® telemetry-compatible heart rate monitoring system
Ports (2):	Type RJ45, interchangeable Network ready connection and Fitness Entertainment port (power compliant with FitLinxx CSAFE specification dated August 4, 2004: 4.75VDC to 10VDC; maximum current of 85mA).
iPod power and charging:	5Vdc @ 500mA
iPod Compatibility:	Play / Pause Volume Control / Mute Previous Track / Next Track (Button Tap) Scan Forward / Scan Back (Button Hold)
Headphone jack:	3.5mm Stereo, 150mW max

Physical Dimensions	
Length:	48.62 in. (123 cm.) <i>with console</i>
Width:	32.5 in. (83 cm.) <i>with console</i>
Height:	66.5 in. (169 cm.) <i>with console</i>
Weight:	177 lbs. (80 kg.) 181 lbs. (82 kg.) <i>with console</i>
Shipping Dimensions (without console)	
Length:	37 in. (94 cm.)
Width:	52 in. (132 cm.)
Height:	32.5 in. (83 cm.)
Weight:	212 lbs. (96 kg.)

7.2 WARRANTY INFORMATION

WARRANTY COVERAGE: CLSL SUMMIT TRAINER

NOTE - Once any commercial product is placed in a private residence (home), it automatically becomes covered under that product category's consumer warranty. Warranty coverage begins at the original date of sale.

WHAT IS COVERED:

This **Life Fitness** commercial exercise equipment ("Product") is warranted to be free of all defects in material and workmanship.

WHO IS COVERED:

The original purchaser or any person receiving the Product as a gift from the original purchaser.

HOW LONG IS IT COVERED:

All coverage is provided by specific Product according to the guidelines listed on the chart accompanying this warranty card.

WHO PAYS TRANSPORTATION & INSURANCE FOR SERVICE:

If the Product or any covered part must be returned to a service facility for repairs, **We, Life Fitness**, will pay all transportation and insurance charges for the first year. **You** are responsible for transportation and insurance charges during the second and third years (if applicable).

WHAT WE WILL DO TO CORRECT COVERED DEFECTS:

We will ship to you any new or rebuilt replacement part or component, or, at our option, replace the Product. Such replacement parts are warranted for the remaining portion of the original warranty period.

WHAT IS NOT COVERED:

Any failures or damage caused by unauthorized service, misuse, accident, negligence, improper assembly or installation, debris resulting from any construction activities in the Product's environment, rust or corrosion as a result of the Product's location, alterations or modifications without our written authorization or by failure on your part to use, operate and maintain the Product as set out in your Operation Manual ("Manual").

Two type RJ45 interchangeable Network ready and Fitness Entertainment ports are supplied with the Product. These ports comply with the FitLinxx CSAFE specification dated August 4, 2004 stating: 4.75VDC to 10VDC; maximum current of 85mA. Any Product damage caused by a load exceeding this FitLinxx CSAFE specification is not covered by warranty.

All terms of this warranty are void if this product is moved beyond the continental borders of the United States of America (excluding Alaska, Hawaii and Canada) and are then subject to the terms provided by that country's local authorized Life Fitness representative.

WHAT YOU MUST DO:

Retain proof of purchase (our receipt of the attached registration card assures registration of purchase information but is not required);

use, operate and maintain the Product as specified in the Manual;

notify Customer Support Services of any defect within 10 days after discovery of the defect; if instructed,

return any defective part for replacement or, if necessary, the entire Product for repair.

OPERATION MANUAL:

It is **VERY IMPORTANT THAT YOU READ THE MANUAL** before operating the Product. Remember to perform the periodic maintenance requirements specified in the Manual to assure proper operation and your continued satisfaction.

HOW TO GET REPLACEMENT PARTS & SERVICE:

Simply call Customer Support Services at **(800) 351-3737** or **(847) 451-0036**, Monday through Friday from 8:00 a.m. to 6:00 p.m. Central Standard Time, and tell them your name, address and the serial number of your product (refer to page 1 for Customer Services contact information). They will tell you how to get a replacement part, or, if necessary, arrange for service where your product is located or advise you on how and where to ship the product for service.

Before shipping:

1. **obtain** a Return Authorization Number (**RA#**) from Customer Support Services
2. securely **pack** your console (use the original shipping carton, if possible)
3. **write** the **RA#** on the outside of the carton
4. **insure** the console, and
5. **include** a letter explaining the defect or problem and a copy of your proof of purchase if you believe the service is covered by warranty

EXCLUSIVE WARRANTY:

THIS LIMITED WARRANTY IS IN LIEU OF ALL OTHER WARRANTIES OF ANY KIND EITHER EXPRESSED OR IMPLIED, INCLUDING BUT NOT LIMITED TO THE IMPLIED WARRANTIES OF MERCHANTABILITY AND FITNESS FOR A PARTICULAR PURPOSE, AND ALL OTHER OBLIGATIONS OR LIABILITIES ON OUR PART. We neither assume nor authorize any person to assure for us any other obligation or liability concerning the sale of this Product. Under no circumstances shall we be liable under this warranty, or otherwise, of any damage to any person or property, including any lost profits or lost savings, for any special, indirect, secondary, incidental or consequential damages of any nature arising out of the use of or inability to use this Product. Some states do not allow the exclusion or limitation of implied warranties or of liability for incidental or consequential damages, so the above limitations or exclusions may not apply to you.

CHANGES IN WARRANTY NOT AUTHORIZED:

No one is authorized to change, modify or extend the terms of this limited warranty.

EFFECT OF STATE LAWS:

This warranty gives you specific legal rights and you may have other rights which vary from state to state.

OUR PLEDGE TO YOU:

Our Products are designed and manufactured to the highest standards.

We want you completely satisfied with our Products and will do everything possible under the terms of this warranty to keep you secure in knowing you have bought the best!

MODEL	2 Years	1 Year	6 Months
CLSL Summit-Trainer	✓ Electrical & Mechanical Parts	✓ Labor	✓ Console Overlay ✓ Shrouds